

Manual No. 900319
Revision
July 21, 2000

**NONINCENDIVE
INDUSTRIAL
METERING UNIT
MODEL II/S
(SERIAL PORT)
INSTALLATION
MANUAL**

METRETEK

COPYRIGHT © 2000 by Metrotek, Incorporated

All rights to this document, domestic and international, are reserved by Metrotek, Incorporated. No part of this publication may be reproduced, stored in a retrieval system, or transmitted in any form or by any means (electronic, mechanical, photocopying, recording, or otherwise) without the prior written permission of Metrotek, Incorporated. Requests for permission to reproduce or distribute this manual should be addressed to:

PUBLICATIONS DEPARTMENT
METROTEK, INCORPORATED
300 NORTH DRIVE
MELBOURNE, FL 32934

The trademark AIS ® is registered (with the) United States Patent and Trademark Office.

Table of Contents

| | |
|--|------------|
| CHAPTER ONE: INTRODUCTION TO THE MANUAL | 1-1 |
| PRODUCT DESCRIPTION | 1-1 |
| Industrial Metering Unit Model II/Serial..... | 1-1 |
| Dual Port IMU-II/S..... | 1-2 |
| WARRANTY INFORMATION | 1-2 |
| TELECOM AND SAFETY NOTIFICATIONS..... | 1-3 |
| Canadian Telecom | 1-3 |
| US Telecom | 1-3 |
| IMPORTANT SAFETY INSTRUCTIONS | 1-4 |
| SCOPE OF MANUAL..... | 1-4 |
| Chapter One: Introduction to the Manual..... | 1-5 |
| Chapter Two: Pre-Installation..... | 1-5 |
| Chapter Three: Installation of the IMU-II/S | 1-5 |
| Chapter Four: IMU-II/S Operation..... | 1-5 |
| Chapter Five: On-Site Troubleshooting..... | 1-6 |
| Chapter Six: Maintenance | 1-6 |
| Chapter Seven: Return Equipment Procedure..... | 1-6 |
| LIST OF ABBREVIATED TERMS | 1-6 |
| CHAPTER TWO: PRE-INSTALLATION..... | 2-1 |
| INTRODUCTION..... | 2-1 |
| LIST OF MATERIALS..... | 2-1 |
| Materials Provided by Metretek | 2-2 |
| Materials Purchased from Metretek | 2-2 |
| Materials Provided by Customer..... | 2-2 |
| LIST OF TOOLS..... | 2-3 |

| | |
|---|------------|
| EQUIPMENT SETUP | 2-3 |
| OBTAIN A LIST CONTAINING SITE INFORMATION | 2-3 |
| VERIFY TELEPHONE LINE INSTALLATION | 2-4 |
| HAZARDOUS AREA INSTALLATION | 2-4 |
| CHAPTER THREE: INSTALLATION OF THE IMU-II/S..... | 3-1 |
| INTRODUCTION..... | 3-1 |
| MOUNT EQUIPMENT..... | 3-2 |
| INSTALL CABLES | 3-2 |
| Telephone Line Station Protector Installation..... | 3-3 |
| Attach Input Cables | 3-6 |
| Serial Data Connection..... | 3-8 |
| Serial Port Multiplexer Connection..... | 3-9 |
| VERIFY RING DETECT JUMPER..... | 3-10 |
| INSTALL POWER SOURCE..... | 3-10 |
| VERIFY POWER UP..... | 3-11 |
| PROGRAM IMU-II/S | 3-11 |
| VERIFY OPERATION OF IMU-II/S..... | 3-11 |
| Verifying Auto-Answer | 3-12 |
| Verify Auto-Dial Operation..... | 3-13 |
| CLOSE THE IMU-II/S..... | 3-14 |
| CHAPTER FOUR: IMU-II/S OPERATIONS | 4-1 |
| INTRODUCTION..... | 4-1 |
| IMU-II/S COMMUNICATIONS | 4-1 |
| Communications Parameters | 4-1 |
| Standard IMU-II/S Communications | 4-2 |
| Dual Port IMU-II/S Communications | 4-2 |

| | |
|---|------------|
| AT Command Set Compatibility | 4-6 |
| IMU-II/S ALARMS - STATUS FLAGS..... | 4-7 |
| TRANSPARENT MODE ALARM MAINTENANCE COMMANDS..... | 4-8 |
| CHAPTER FIVE: ON-SITE TROUBLESHOOTING..... | 5-1 |
| INTRODUCTION..... | 5-1 |
| GENERAL TROUBLESHOOTING | 5-1 |
| Check for the Telephone Line Dial Tone | 5-1 |
| Check Battery Voltage | 5-1 |
| Reset the IMU-II/S..... | 5-2 |
| ADDITIONAL AUTO-ANSWER TROUBLESHOOTING | 5-3 |
| ADDITIONAL AUTO-DIALING TROUBLESHOOTING | 5-3 |
| NO COMMUNICATION WITH DTE | 5-4 |
| CHAPTER SIX: MAINTENANCE | 6-1 |
| INTRODUCTION..... | 6-1 |
| BATTERY | 6-1 |
| Lithium Battery Replacement..... | 6-1 |
| CHAPTER SEVEN: RETURN EQUIPMENT PROCEDURE..... | 7-1 |
| INTRODUCTION..... | 7-1 |
| RETURN EQUIPMENT PROCEDURE | 7-1 |
| APPENDIX A: PRODUCT SPECIFICATIONS..... | A-1 |
| Telephone Interface Specifications: | A-2 |
| APPENDIX B: TII STATION PROTECTOR | B-1 |

List of Illustrations

| | |
|---|------|
| Figure 2-1. Lithium Battery IMU-II/S..... | 2-1 |
| Figure 2-2. Optional Serial Port Multiplexer | 2-2 |
| Figure 3-1. IMU-II/S Mounting Dimensions | 3-2 |
| Figure 3-2. IMU-II/S Input Control Drawing..... | 3-4 |
| Figure 3-3. IMU-II/S Terminal Strip | 3-7 |
| Figure 3-4. IMU-II/S Serial Port Multiplexer Terminal Strip | 3-7 |
| Figure 3-5. IMU-II/S Board | 3-8 |
| Figure 3-6. Lithium Battery Powered IMU-II/S..... | 3-10 |
| Figure 4-1. AT Command Call Origination..... | 4-4 |
| Figure 4-2. Dual Port IMU-II/S Answering | 4-5 |
| Figure 5-1. IMU-II/S Board | 5-3 |

List of Tables

| | |
|---|------|
| Table 3-1. LED Functions | 3-13 |
| Table 4-1. IMU-II/S At Commands..... | 4-6 |
| Table 4-2. IMU-II/S Valid AT Result Codes | 4-7 |
| Table 4-3. IMU-II/S Status Flags..... | 4-9 |

CHAPTER ONE: INTRODUCTION TO THE MANUAL

PURPOSE OF MANUAL

This document provides instructions for the installation of Metrotek's Industrial Metering Unit Model-II/Serial module for gas applications in a hazardous Class I, Division 2 location as specified in the National Electric Code (NEC) 500-5(b). The installation instructions contained in this manual for the nonincendive IMU-II/S must be followed as stated without deviation to ensure compliance with the UL approved listing.

PRODUCT DESCRIPTION

Industrial Metering Unit Model II/Serial

The Industrial Metering Unit Model II/Serial (IMU-II/S) is the remote solid state recorder part of a reliable automatic data collection system. The IMU-II/S is designed to collect pulse data from up to two inputs and store the data as a function of time (time-tagged interval data). The pulse data detected on these two inputs is also stored in an accumulator register and can be used to track a meter index. The IMU-II/S has 32K bytes of RAM which will allow 70 days of data storage when collecting 15 minute data from two inputs. The IMU-II/S will attempt to call the central computer when its memory is 75% full (52.5 days when collecting 15 minute data) so that no data will be overwritten and lost. This information is stored at the central computer where it is available for analysis and display.

At a preprogrammed time or when an alarm is detected, the IMU-II/S dials the central computer and transfers the collected information plus any alarm data via standard telephone lines. If the IMU-II/S is unable to successfully complete the call it will go into its predetermined call retry mode and attempt to communicate the data to the host computer at a later time.

The IMU-II/S can also be used as a modem to remotely access field data collection devices (Data Terminal Equipment (DTE) such as electronic correctors, flow computers, etc.) that have a RS-232 channel. The IMU-II/S is capable of communicating at rates of 300, 1200, and 2400 bits/sec.

The IMU-II/S can also be controlled by the DTE device using AT compatible commands. The DTE can awaken the IMU-II/S using the DTR control line and then use AT commands to force the IMU-II/S to dial and connect with a host modem.

For further information on the IMU-II/S's capabilities, please refer to Chapter 4 entitled "IMU-II/S Operation".

Dual Port IMU-II/S

The Dual Port IMU-II/S consists of the standard IMU-II/S with the optional Serial Port Multiplexer (SPM) installed. The SPM plugs into the IMU-II/S's input terminal block and allows a single IMU-II/S to communicate with two DTE devices via their RS-232 ports. Both the DTE serial ports can be individually addressed from the host modem by sending a port select command to the IMU-II/S.

The dual port capability must be enabled in the IMU-II/S via the Metretek Programmer.

WARRANTY INFORMATION

The seller warrants its hardware to be free from defects in material and workmanship under normal and proper use for a period of 12 months from the date the hardware is shipped from Metretek, Incorporated. The seller's sole liability and the buyer's sole remedy for any breach of the foregoing provision is, at the seller's option, the timely no-charge repair or replacement of any defective hardware or part that Metretek inspects and finds reasonable evidence that a defect in material or workmanship exists. The buyer shall provide the labor required to remove the defective hardware and install its replacement at no charge to the seller. The equipment will be shipped to the seller at the buyer's expense. The replacement or repaired equipment will be shipped to the buyer at the seller's expense.

Warranty claims to be honored under this warranty must be made promptly. Such claims shall specify the nature and details of the claim, the date that the cause of the claim was first observed, and the affected equipment's unit serial number. Defective equipment shall not be returned to the seller's factory without prior authorization from the seller. A copy of the claim's documentation must be attached to the defective equipment and sent to the seller's manufacturing facility. Defective components replaced under this warranty shall become the property of the seller.

The seller makes no representation or warranty other than those set forth in this agreement. THE WARRANTY STATED HEREIN IS EXPRESSLY IN LIEU OF ALL WARRANTIES, EXPRESSED OR IMPLIED, INCLUDING BUT NOT LIMITED TO, ANY EXPRESSED OR IMPLIED WARRANTY OF MERCHANTABILITY OR FITNESS FOR A PARTICULAR PURPOSE. SUCH WARRANTY CONSTITUTES THE ONLY WARRANTY MADE BY THE SELLER WITH RESPECT TO THIS AGREEMENT, THE EQUIPMENT UNITS, OR THE SERVICES TO BE SUPPLIED HEREBY. THE SELLER SHALL NOT BE LIABLE FOR ANY INCIDENTAL OR CONSEQUENTIAL DAMAGES OF ANY KIND.

This warranty will not extend to equipment subjected to accident, to misuse, or to alterations/repair not made and documented in writing by Metretek.

TELECOM AND SAFETY NOTIFICATIONS

Canadian Telecom

"NOTICE: The Industry Canada label identifies certified equipment. This certification means that the equipment meets certain telecommunications network protective, operational and safety requirements as prescribed in the appropriate Terminal Equipment Technical Requirements documents. The Department does not guarantee the equipment will operate to the user's satisfaction.

Before installing this equipment, users should ensure that it is permissible to be connected to the facilities of the local telecommunications company. The equipment must also be installed using an acceptable method of connection. The customer should be aware that compliance with the above conditions may not prevent degradation of service in some situations.

Repairs to certified equipment should be coordinated by a representative designated by the supplier. Any repairs or alterations made by the user to this equipment, or equipment malfunctions, may give the telecommunications company cause to request the user to disconnect the equipment.

Users should ensure for their own protection that the electrical ground connections of the power utility, telephone lines and internal metallic water pipe system, if present, are connected together. This precaution may be particularly important in rural areas.

CAUTION

Users should not attempt to make such connections themselves, but should contact the appropriate electric inspection authority, or electrician, as appropriate.

Use only Canadian telecom jack type CA11A when connecting to the telephone network.

The Ringer Equivalence Number (REN) of this device is 0.3B.

NOTICE: The **Ringer Equivalence Number (REN)** assigned to each terminal device provides an indication of the maximum number of terminals allowed to be connected to a telephone interface. The termination of an interface may consist of any combination of devices subject only to the requirement that the sum of the Ringer Equivalence Numbers of all the devices does not exceed 5.

US Telecom

This equipment complies with Part 68 of the FCC rules. On the front of this equipment is a label that includes the FCC registration number and ringer equivalence number (REN) for this equipment. If requested, this information must be provided to the telephone company.

The REN is used to determine the quantity of devices which may be connected to the telephone line. Excessive RENs on the telephone line may result in the devices not ringing in response to an incoming call. In most areas, the number of RENs should not exceed five (5.0). To determine the number of RENs that may be connected to the line in a calling area - (maximum REN) - contact the telephone company.

This equipment uses the following USOC jacks: RJ11C

This equipment is designed to connect to the telephone network or premises wiring using a compatible modular jack that is Part 68 compliant.

If this equipment causes harm to the telephone network, the telephone company will notify you in advance that temporary discontinuance of service may be required. If advance notice isn't practical, the telephone company will notify you as soon as possible. Also, you will be advised of your right to file a complaint with the FCC.

The telephone company may make changes in its facilities, equipment, operations, or procedures that could affect the operation of the equipment. If this happens, the telephone company will provide advance notice in order for you to make the necessary modifications in order to maintain uninterrupted service.

If trouble is experienced with this equipment, please contact Metretek Technical Support at (800) 327-8559 for repair and warranty information. If the trouble is causing harm to the telephone network, the telephone company may ask you to remove the equipment from the network until the problem is resolved.

IMPORTANT SAFETY INSTRUCTIONS

When using your telephone equipment, basic safety precautions should always be followed to reduce the risk of fire, electric shock and injury to persons, including the following:

1. Read and understand all instructions.
2. Follow all warnings and instructions marked on the product.
3. This product should be operated only from the type of power source indicated on the marking label. If you are not sure of the type of power supply to your home, consult your dealer or local power company.
4. To reduce the risk of electric shock, do not disassemble this product, but return it to Metretek when service or repair work is required. Incorrect reassembly can cause electric shock when the unit is subsequently used.

SAVE THESE INSTRUCTIONS

FCC Part 15 Notification

This equipment has been tested and found to comply with the limits for a Class B digital device, pursuant to Part 15 of the FCC Rules. These limits are designed to provide reasonable protection against harmful interference in a residential installation. This equipment generates, uses and can radiate radio frequency energy and, if not installed and used in accordance with the instructions, may cause harmful interference to radio communications. However, there is no guarantee that interference will not occur in a particular installation. If this equipment does cause harmful interference to radio or television reception, which can be determined by turning the equipment off and on, the user is encouraged to try to correct the interference by one or more of the following measures:

- Reorient or relocate the receiving antenna.
- Increase the separation between the equipment and receiver.
- Connect the equipment into an outlet on a circuit different from that to which the receiver is connected
- Consult the dealer or an experienced radio/TV technician for help.

Any changes made by the user not approved by Metrotek can void the user's authority to operate the equipment.

SCOPE OF MANUAL

This manual is divided into six chapters. Listed below is a brief description of each chapter.

Chapter One: Introduction to the Manual

This chapter explains the purpose of this manual and summarizes each chapter. In addition, a list of abbreviated terms and reference documents that are used within this manual are given.

Chapter Two: Pre-Installation

This chapter provides installation instructions that must be completed before installing the IMU-II/S in the field. A list of materials and tools are also provided.

Chapter Three: Installation of the IMU-II/S

This chapter provides installation instructions for the IMU-II/S in the field. It will discuss how to install the battery, the cables, and how to program the IMU-II/S.

Chapter Four: IMU-II/S Operation

This chapter describes the operation of the IMU-II/S and how it can be used to facilitate communications between the host computer and a DTE device.

Chapter Five: On-Site Troubleshooting

This chapter provides steps to follow when troubleshooting a IMU-II/S.

Chapter Six: Maintenance

This chapter provides maintenance directions for the IMU-II/S.

Chapter Seven: Return Equipment Procedure

This chapter provides steps to return your equipment to Metretek.

LIST OF ABBREVIATED TERMS

A list of the abbreviated terms found in this manual are given below:

AWG - American Wire Gauge

CSA - Canadian Standards Association

DTE - Data Terminal Equipment

EC-AT - Electronic Corrector with Audit Trail

FCC - Federal Communication Commission

IC - Integrated Circuit

IMU/S - Industrial Metering Unit Model II/Serial

LED - Light Emitting Diode

SPM - Serial Port Multiplexer

CHAPTER TWO: PRE-INSTALLATION

INTRODUCTION

This chapter outlines the necessary materials and the preliminary steps that must be completed before the installation can be performed. Please review this section before going to the field.

LIST OF MATERIALS

This section lists the materials which are provided by Metrotek and the materials which the customer must provide before the installation of the IMU-II/S in the field. Figure 2-1 illustrates the lithium battery powered IMU-II/S. Figure 2-2 illustrates the optional Serial Port Multiplexer.

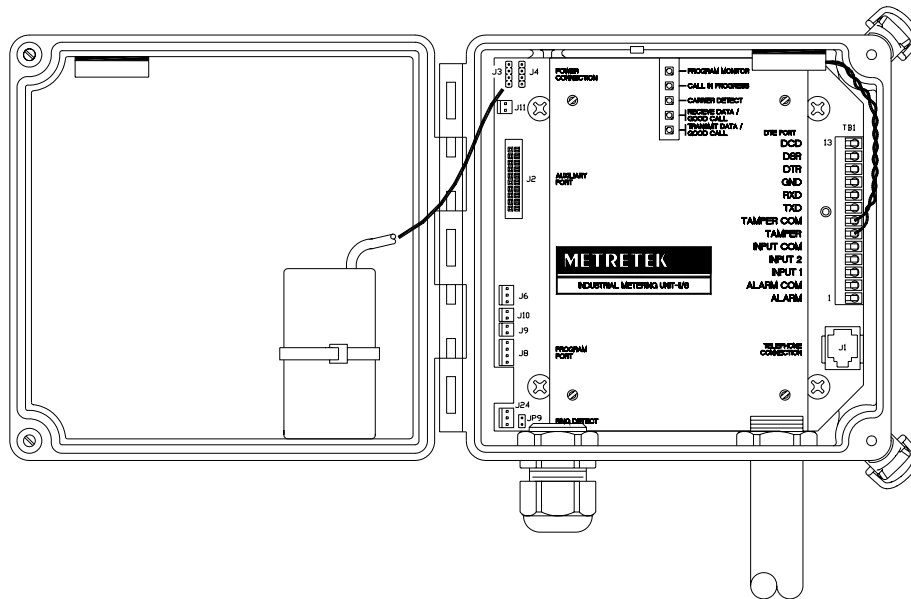

Figure 2-1. Lithium Battery IMU-II/S

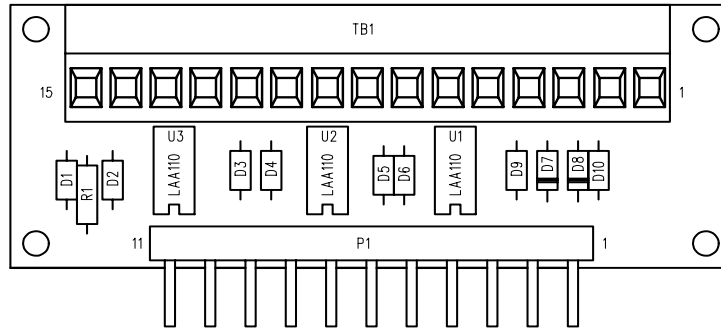

Figure 2-2. Optional Serial Port Multiplexer

NOTE

When using the Serial Port Multiplexer, the board should be plugged into terminal positions 3 through 13 on the IMU-II/S board.

Before leaving for the field, you should verify that you have all of the materials listed below:

Materials Provided by Metretek

1. Metretek IMU-II/S
2. Batteries Metretek Lithium Battery Pack Stock No. 6135-0022B-001
3. TII telephone line station protector

Materials Purchased from Metretek

1. One copy of Metretek Programmer Software (Used with a laptop PC and a Metretek Serial Interface Cable to program/configure the IMU-II/S) with users manual no. 900203
2. One Metretek Serial Interface Cable - Metretek Stock No. 1002-0151C-001

Materials Provided by Customer

1. Cables
 - For connecting earth ground to the TII telephone line station protector
Recommend: Insulated, No. 12 AWG solid copper, green wire
 - For connecting the IMU-II/S to the TII telephone line station protector and the telephone network interface
Recommend: 24 AWG, 4 connector solid phone cable (Carol P/N C4424)
RJII telephone plugs (KYCON P/N MP 64R-5000S)

- For connecting the IMU-II/S to the DTE's serial port
 Recommend: 3 conductor insulated shielded cable, stranded, No. 20 AWG
 Alpha P/N 35463
 or 4 conductor insulated shielded cable, stranded, No. 20 AWG
 Alpha P/N 35464
 - For connecting alarm switches to IMU-II/S alarm inputs
 Recommend: 2 conductor insulated cable, stranded, No. 20 AWG
 Alpha P/N 1172
2. One IBM PC compatible laptop computer (MS-DOS Version 3.30 or higher) with a standard RS-232 serial port (Note: For programming/configuration of IMU-II/S)
 3. Conduit

LIST OF TOOLS

1. A 1/8-inch flat-blade screwdriver for terminal strip
2. A multimeter
3. A telephone test set
4. Wire strippers and cutters capable of stripping a 12-24 AWG wire
5. RJ-11 plug installation tool - AMP Incorporated Part No. 1-231652-0

EQUIPMENT SETUP

Before going to the field to install your equipment, you should complete these steps:

1. Obtain a list containing site information
2. Verify telephone line installation

OBTAIN A LIST CONTAINING SITE INFORMATION

A list containing the following information will be useful for each IMU-II/S you are installing in the field:

- Phone number of the central computer (If the unit will be enabled to auto-dial)
- Customer's address/meter location

- The IMU-II/S's enclosure serial number
- Utility's account billing number

VERIFY TELEPHONE LINE INSTALLATION

Before leaving to install the IMU-II/S, verify that the telephone line has been installed at each site where you are placing a IMU-II/S.

CAUTION

This unit does not work on digital phone systems. Hooking unit to a digital phone system could damage the unit.

HAZARDOUS AREA INSTALLATION

The IMU-II/S is classified as a nonincendive device. The IMU-II/S can be installed in a Class I, Division 2 hazardous area if installed as directed in this manual and as shown in Figure 3-2. The IMU-II/S is not classified as intrinsically safe and cannot be installed in a Class I, Division 1 hazardous area.

CHAPTER THREE: INSTALLATION OF THE IMU-II/S

INTRODUCTION

This chapter explains how to install the IMU-II/S in the field. Refer to Appendix B for the IMU-II/S specifications.

NOTE

If installing a UL Listed IMU-II/S in a Class I Division 2 area, follow the Division 2 wiring method as specified in Section 501-4(b) of the National Electric Code (NEC), NFPA, 70.

WARNING

- Never install telephone wiring during a lightning storm.
- Never install telephone jacks in wet locations unless the jack is specifically designed for wet locations.
- Never touch uninsulated telephone wires or terminals unless the telephone line has been disconnected at the network interface.
- Use caution when installing or modifying telephone lines.

MOUNT EQUIPMENT

Attach the IMU-II/S to a wall or pipe from the meter. Figure 3-1 shows the dimensions of the IMU-II/S.

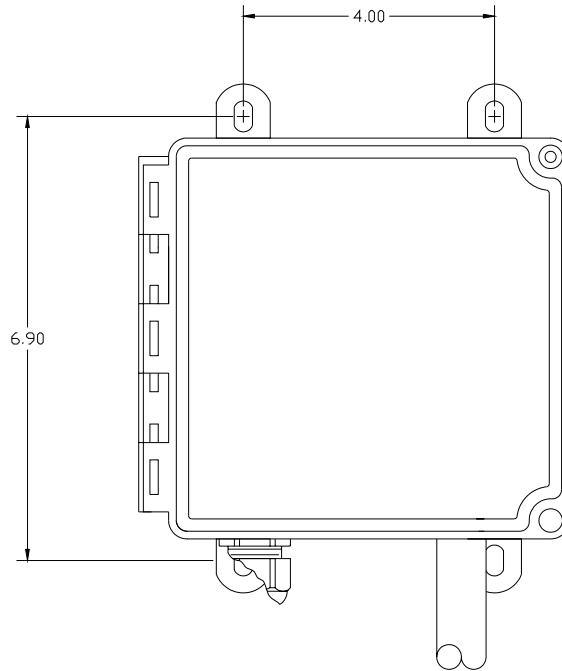

Figure 3-1. IMU-II/S Mounting Dimensions

INSTALL CABLES

The cables needed are:

- Pulse Data and Alarm cables
- Grounding cable
- Serial interface cable(s)

WARNING

Do not disconnect or connect live circuits unless area is known to be nonhazardous.

1. Installation of the IMU-II/S and connection of all inputs to the unit must be made as shown in Figure 3-2, IMU-II/S Control Drawing.

2. Feed the pulse input cables and the alarm cables through the left entry hole on the bottom of the IMU-II/S. If a serial data input cable is also being connected to the IMU-II/S these wires must enter the enclosure using conduit as shown in Figure 3-2. If the unit is not connecting to a serial input cable the dry contact pulse inputs may enter the enclosure through a bushing (conduit not required).
3. Remove the conduit plug from the right entry hole on the bottom of the IMU-II/S.

NOTE

The telephone line must enter the enclosure through 1/2"N.P.T. conduit using an approved Division 2 wiring method as specified in Section 501-4(b) of the National Electric Code (NEC), NFPA, 70. Metretek recommends using a 1/2" sealing locknut (with PVC molded seal) on the outside of the box as shown in Figure 3-2.

4. Feed the telephone cable through the conduit of the IMU-II/S. Install a RJ-11 plug onto the telephone cable. Verify that the red and green wires are connected to the two inside pins of the RJ-11 plug. These two wires are the Tip and Ring wires and are used by the IMU-II/S to connect to the telephone network.

Telephone Line Station Protector Installation

Follow the steps below to install the telephone line station protector and to make final connection to the phone line.

1. Install the telephone receptacle (telephone network interface) if it has not been previously installed.

CLASS I, DIVISION 2, GROUP D AREA INSTALLATION

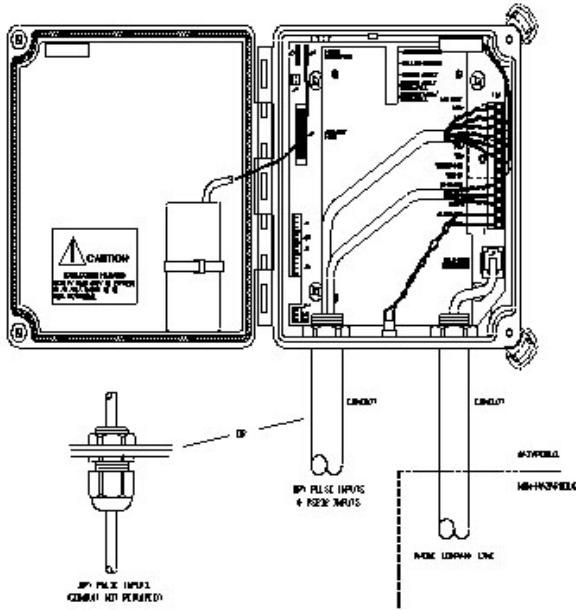

- NOTES
1. ALL WIRING AND TERMINALS USED IN THIS DRAWING ARE AS SHOWN IN THE MANUFACTURER'S LITERATURE FOR A CLASS I, DIVISION 2 AREA, IN ACCORDANCE WITH THE NATIONAL ELECTRICAL CODE, ARTICLE 501.40(B)(1).
 2. ALL THE CONDUIT SHALL BE ONE SIZE OVER THE WIRE SIZE, BUT 2 WIRE SIZES, IF ANY, SHALL BE ALLOWED TO BE IN THE CONDUIT AND, IT MUST BE INSTALLED FOR CLASS I, DIVISION 2.
 3. DO NOT DRAG ANY WIRE OR CONDUIT OVER ANY OBJECTS OR OVER ANY SURFACE THAT IS NOT SMOOTH OR THAT IS NOT NON-SPARKING.
 4. ONLY THE WELDING SYSTEM MAY BE USED.

| | |
|--------------------|-------------------|
| WIRING SYSTEM NAME | WIRING SYSTEM NO. |
|--------------------|-------------------|

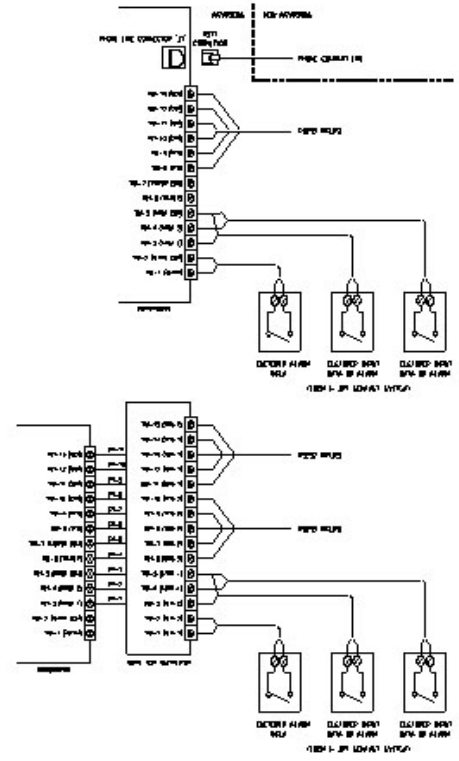

WIRING DIAGRAM

PRELIMINARY
APPROVALS REQUIRED

| REVISIONS | | DATE | | BY | |
|-----------|--|------|--|----|--|
| | | | | | |

| | | | |
|--|--|---|--|
| ALL WIRING AND TERMINALS USED IN THIS DRAWING ARE AS SHOWN IN THE MANUFACTURER'S LITERATURE FOR A CLASS I, DIVISION 2 AREA, IN ACCORDANCE WITH THE NATIONAL ELECTRICAL CODE, ARTICLE 501.40(B)(1). | | METWORKS 14000 W. 140TH ST. CHICAGO, IL 60641 | |
| CONTROL DRAWING IMU-11/5, UL APPROVED MONITOR RELAY (CL-1, DIV-2, EXP-D) | | DATE: 4/20/73 DRAWN BY: [Signature] CHECKED BY: [Signature] | |

2. Mount the TII Telephone Station Protector in a suitable location. Wiring of the station protector is shown below:

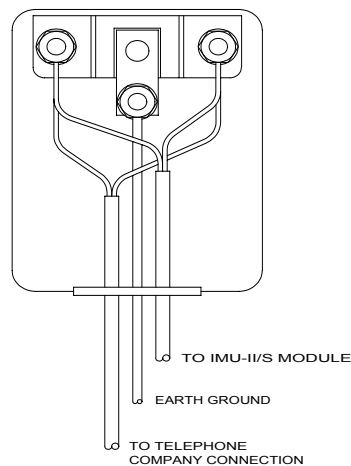

NOTE

TII Station Protector should not be installed in a Class I Division 2 area.

3. Connect one end of the 12 AWG earth ground wire to the center terminal on the TII protector. Appendix B provides a data sheet detailing the TII Telephone Station Protector.
4. Connect the other end of the earth ground wire to a solid earth ground in conformance with national and local electrical code regulations.
5. Route the telephone cables from the telephone company connector and the IMU-II/S through the bottom of the TII station protector.
6. Connect the red wires from both of the telephone cables to the left screw inside the TII station protector.
7. Connect the green wires from both of the telephone cables to the right screw inside the TII station protector.
8. Connect the telephone test set to the telephone line plug going to the IMU-II/S board.
9. Check for a dial tone. (This procedure will test the telephone cable and the telephone line.)

NOTE

If no dial tone is detected, a problem exists with the telephone line which must be repaired before continuing the IMU-II/S installation process.

10. If the IMU-II/S is to be enabled to auto-dial, dial the telephone number assigned to the central modem.
11. Listen to the telephone receiver to verify that the central modem answers the call and responds with an answer tone.
12. Disconnect the telephone test set.

Attach Input Cables

Connection of the three data and alarm cables to the terminal strip are described below. You may unplug the terminal strip from the unit for easier access when making these connections. Figure 3-3 shows the standard IMU-II/S terminal strip. Figure 3-4 shows the IMU-II/S optional Serial Port Multiplexer terminal Strip. Figure 3-2 illustrates how the data, alarm, and telephone cables should be routed and attached to the IMU-II/S. Please refer to Chapter Four for more information on the IMU-II/S alarms.

- **Input 1**

Input 1, (TB1-3, TB1-5), can be configured by the Metretek Programmer as either a Form A pulse counting data input or a Form A alarm input. The input transducer must provide an input closure of greater than 40 msec.

- **Input 2**

Input 2, (TB1-4, TB1-5), can be configured by the Metretek Programmer as either a Form A pulse counting data input or a Form A alarm input. The input transducer must provide an input closure of greater than 40 msec.

- **Alarm**

The Alarm input, (TB1-1, TB1-2), is a normally open alarm input and can be wired as a customer specified alarm. The alarm transducer must provide an input closure of greater than 40 msec.

- **Tamper**

Tamp+ is a normally closed alarm input and is usually prewired from the factory as a tamper alarm and is connected to the magnetic switch found on the IMU-II/S enclosure side wall.

NOTE

If the transducer outputs are polarity sensitive, connect the negative side of the output to the common or negative input connection.

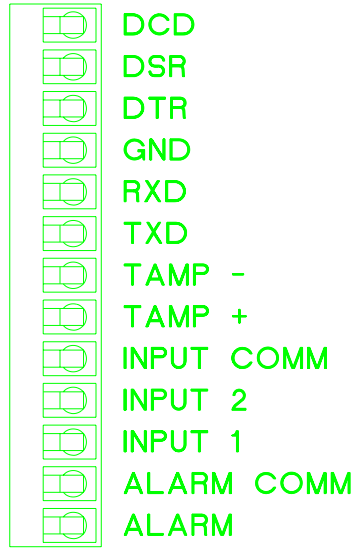

Figure 3-3. IMU-II/S Terminal Strip

| SERIAL PORT MULTIPLEXER - TB1 | | | | | | | | | | | | | | |
|-------------------------------|-------|-------|-------|-------|-------|-------|-------|-------|-------|--------|--------|---------|-------|-------|
| 15 | 14 | 13 | 12 | 11 | 10 | 9 | 8 | 7 | 6 | 5 | 4 | 3 | 2 | 1 |
| TXD 1 | RXD 1 | DSR 1 | DTR 1 | GND 1 | TXD 2 | RXD 2 | DSR 2 | DTR 2 | GND 2 | TAMP - | TAMP + | INP COM | INP 2 | INP 1 |

Figure 3-4. IMU-II/S Serial Port Multiplexer Terminal Strip

NOTE

When using the Serial Port Multiplexer, the board should be plugged into terminal positions 3 through 13 on the IMU-II/S board.

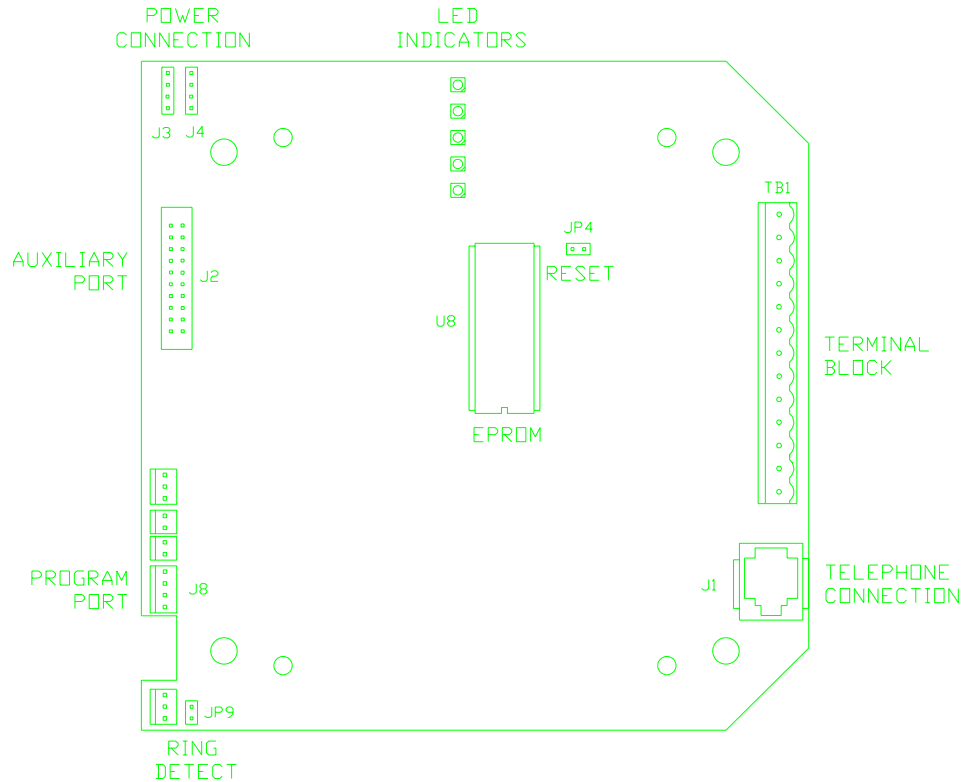

Figure 3-5. IMU-II/S Board

Serial Data Connection

The connection of the DTE's serial port to the IMU-II/S is made through the IMU-II/S's terminal strip.

The serial data cables must enter the enclosure through 1/2"N.P.T. conduit using an approved Division 2 wiring method as specified in Section 501-4(b) of the National Electric Code (NEC), NFPA, 70. Metretek recommends using a 1/2" sealing locknut (with PVC molded seal) on the outside of the box shown in Figure 3-2.

You may unplug the terminal strip from the unit for easier access while making these connections.

The following RS-232 signals are present on the Standard IMU-II/S:

- | | | |
|--------|--------|--|
| 1. TXD | Output | Transmit Data from IMU-II/S. |
| 2. RXD | Input | Receive Data to IMU-II/S. |
| 3. DSR | Output | Data Set Ready - Set high by IMU-II/S when ready to communicate. |

- | | | | |
|----|-----|--------|---|
| 4. | DTR | Input | Data Terminal Ready - Set high by DTE when the DTE wishes to communicate. Wakes IMU-II/S from idle. |
| 5. | DCD | Output | Carrier Detect - Set high by IMU-II/S when carrier is detected. |

The following RS-232 signals are present on the IMU-II/S with the Serial Port Multiplexer (The Serial Port Multiplexer board should be plugged into terminal positions 3 through 13 on the IMU-II/S board.) installed:

- | | | | |
|----|------|--------|--|
| 1. | TXD1 | Output | Port 1 Transmit Data from IMU-II/S. |
| 2. | RXD1 | Input | Port 1 Receive Data to IMU-II/S. |
| 3. | DSR1 | Output | Port 1 Data Set Ready - Set high by IMU-II/S when ready to communicate. |
| 4. | DTR1 | Input | Port 1 Data Terminal Ready - Set high by DTE when the DTE wishes to communicate. Wakes IMU-II/S from idle. |
| 5. | TXD2 | Output | Port 2 Transmit Data from IMU-II/S. |
| 6. | RXD2 | Input | Port 2 Receive Data to IMU-II/S. |
| 7. | DSR2 | Output | Port 2 Data Set Ready - Set high by IMU-II/S when ready to communicate. |
| 8. | DTR2 | Input | Port 2 Data Terminal Ready - Set high by DTE when the DTE wishes to communicate. Wakes IMU-II/S from idle. |

To connect a DTE serial port to the IMU-II/S, perform the following steps:

1. Feed the serial cable from the DTE through the left entry hole on the IMU-II/S.
2. Connect the DTE's transmit data wire to the IMU-II/S's RXD terminal.
3. Connect the DTE's receive data wire to the IMU-II/S's TXD terminal.
4. Connect the DTE's signal ground wire to the IMU-II/S's GND terminal.
5. If necessary, connect the DTE's data terminal ready wire to the IMU-II/S's DSR terminal.
6. If necessary, connect the DTE's data set ready wire to the IMU-II/S's DTR terminal.
7. If necessary, connect the DTE's carrier detect input wire to the IMU-II/S's DCD terminal. This connection is not available if a Serial Port Multiplexer is installed.

If you are unsure about which signals should be connected, refer to Chapter 4, which explains the operation of the IMU-II/S.

VERIFY RING DETECT JUMPER

Ring Detect allows the IMU-II/S to answer incoming calls from the central computer system. If you requested ring detect capabilities on your IMU-II/S, a jumper should have been installed when it was shipped. Verify that the jumper JP9 on the IMU-II/S board is present. To determine the exact location of JP9, refer to Figure 3-5.

- To enable ring detect, install JP9 on the IMU-II/S board.
- To disable ring detect, remove the jumper JP9 from the IMU-II/S board.

INSTALL POWER SOURCE

This section will explain how to install the lithium battery pack.

WARNING

Do not disconnect or connect batteries unless are is known to be nonhazardous.

1. Install the lithium battery pack on the door of the IMU-II/S enclosure as shown in figure 3-6. Secure the battery with the tie-wraps supplied.
2. Connect the plug from the lithium battery pack to either battery connector, J3 or J4, on the IMU-II/S board. Figure 3-6 shows the exact location of the battery connectors.

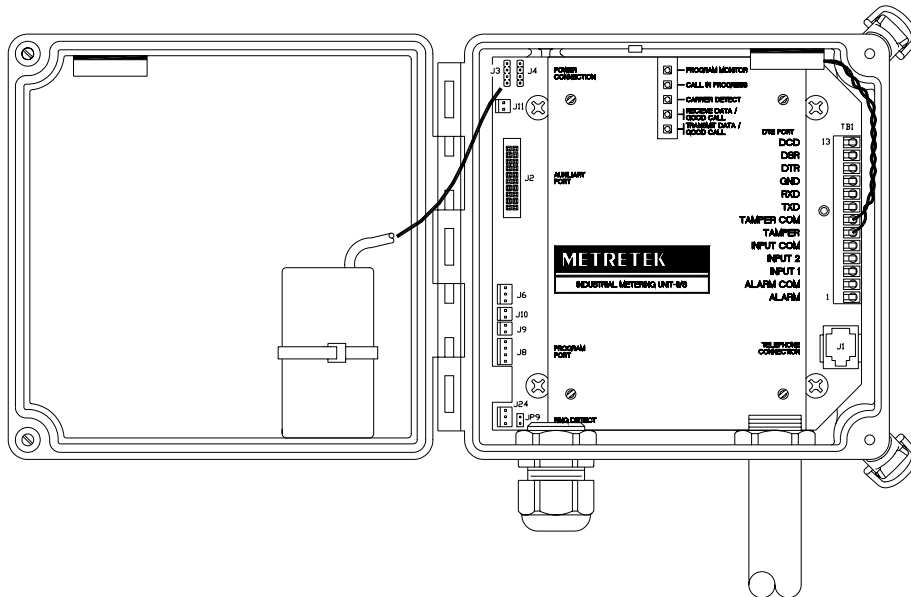

Figure 3-6. Lithium Battery Powered IMU-II/S

VERIFY POWER UP

Immediately after the IMU-II/S is powered up, the FIRMWARE MONITOR LED will turn on solid green while it runs its RAM test. If the RAM test fails the FIRMWARE MONITOR and OFFHOOK LEDs will be turned off and all other LEDs will be turned on. If the test is successful the IMU-II/S will momentarily light the RD LED. The FIRMWARE MONITOR LED will then begin to blink. If the IMU-II/S is enabled to auto-dial, it will immediately go off-hook and attempt to call-in to the central computer modem to report a Unit Reset Alarm.

NOTE

Whenever the IMU-II/S detects a TAMPER alarm (enclosure door open), the LEDs will be activated for 4-1/4 minutes. To re-enable the LEDs after the 4-1/4 minute period has expired, close and reopen the IMU-II/S enclosure.

PROGRAM IMU-II/S

Programming and configuration of the IMU-II/S is accomplished using the Metretek Programmer Software. This software operates on a portable computer and programs the IMU-II/S through the Serial Interface Cable. This cable connects to the IMU-II/S's serial port through which the units phone number, type of dialing, unit identification number, and other parameters are programmed.

WARNING

Do not disconnect or connect live circuits unless area is known to be nonhazardous.

1. Connect the Serial Interface Cable to the IMU-II/S board at J8. Refer to Figure 3-5 for the exact location of the connector.
2. Refer to Manual No. 900203, Metretek Programmer Hardware and Software Users Manual for complete directions on how to program your IMU-II/S.

VERIFY OPERATION OF IMU-II/S

CAUTION

The IMU-II/S cannot communicate with the Metretek Programmer and the central computer modem simultaneously. When the IMU-II/S is being programmed/configured, the unit must not be communicating with the central modem. Likewise when the IMU-II/S is communicating with the central modem, the Serial Interface Cable should not be connected to the IMU-II/S.

Verifying Auto-Answer

If the IMU-II/S is enabled for auto-answer, follow the steps below to verify correct IMU-II/S operation.

1. Connect the IMU-II/S telephone jack J1 and the telephone test set in parallel and then connect them to the telephone company line.
2. Place the telephone test set in the monitor mode.
3. Have the central computer operator call the IMU-II/S using the central modem. This can be accomplished using the DTE manufacturers software, a software communications package such as PROCOMM or the Metretek Data Collection Software.
4. Listen to the call using the telephone test set.
5. After the ring is detected, verify that the OFFHOOK (OH) Light Emitting Diode (LED) located on the IMU-II/S has answered the call. Table 3-1 describes the functions of all the LEDs on the IMU-II/S board.

NOTE

Whenever the IMU-II/S detects a TAMPER alarm (enclosure door open), the LEDs will be activated for 4-1/4 minutes. To re-enable the LEDs after the 4-1/4 minute period has expired, close and reopen the IMU-II/S enclosure.

6. After approximately 5-6 seconds, verify that the CARRIER DETECT (CD) LED lights to signify a good connection with the central computer.

If the OFFHOOK LED or the CARRIER DETECT LED does not light, refer to Chapter Five, On-site Troubleshooting.

| LED NAME | DEFINITION |
|-------------------------------|--|
| 1 (FIRMWARE MONITOR) | Blinks at 1Hz to show that the system is operating properly in Metretek Mode. |
| 2 (CALL IN PROGRESS) | Off-Hook - Lights to indicate the IMU-II/S is off-hook. |
| 3 (CD) | Carrier Detect - Lights to indicate that the IMU-II/S detects a carrier signal from a remote modem. |
| 4 (RECEIVE DATA / GOOD CALL) | Receive Data / Good Call - When the IMU-II/S is off-hook, this LED will light to indicate that the IMU-II/S is receiving data from the central computer. When the IMU-II/S is on-hook, this LED will be lit if communications with the central computer was successful. This LED will be turned off if communications were unsuccessful. |
| 5 (TRANSMIT DATA / GOOD CALL) | Transmit Data / Good Call - When the IMU-II/S is off-hook, this LED will light to indicate that the IMU-II/S is transmitting data to the central computer. When the IMU-II/S is on-hook, this LED will be lit if the communications with the Central Computer was successful. This LED will be turned off if communications were unsuccessful. |

Table 3-1. LED Functions

Verify Auto-Dial Operation

If the IMU-II/S is enabled to auto-dial when an alarm occurs, follow the steps below to verify correct IMU-II/S operation. Two calls may be required to test the IMU-II/S since it may be programmed to auto-dial two different phone numbers.

1. Connect the IMU-II/S telephone jack J1 and the telephone test set in parallel and then connect them to the telephone company line.
2. Place the telephone test set in the monitor mode.
3. To force a test call to phone number 1 (standard IMU-II/S and IMU-II/S with SPM installed), momentarily short the alarm input (TB1-1 to TB1-2). If the IMU-II/S is configured for dual serial ports and Input 2 is configured as an alarm input you can trigger a call to phone number 2 by momentarily shorting the Input 2 terminal to the Input common terminal (TB1-4 to TB1-5).
4. Listen to the call with the telephone test set.
5. Verify that the OFFHOOK (OH) Light Emitting Diode (LED) located on the IMU-II/S board illuminates signifying that the IMU-II/S has gone OFFHOOK to dial the central computer's telephone number. Table 3-1 describes the function of the LED's on the IMU-II/S board.

NOTE

Whenever the IMU-II/S detects a TAMPER alarm (enclosure door open), the LEDs will be activated for 4-1/4 minutes. To re-enable the LEDs after the 4-1/4 minute period has expired, close and reopen the IMU-II/S enclosure.

6. After dialing the central computer's phone number and connecting with the central modem, the IMU-II/S's CARRIER DETECT (CD) LED should illuminate signifying a good connection with the central computer.

If the OFFHOOK or the CARRIER DETECT indicator do not light, refer to Chapter Five, On-site Troubleshooting.

CLOSE THE IMU-II/S

To close the IMU-II/S, perform the following steps:

1. Disconnect the telephone test from the telephone jack.
2. Plug the telephone cable for the IMU-II/S into J1 on the IMU-II/S board.
3. Tighten the bushing on the bottom of the IMU-II/S.
4. Close and latch the door of the IMU-II/S enclosure.
5. Padlock the IMU-II/S enclosure and attach a security seal (optional).

CHAPTER FOUR: IMU-II/S OPERATIONS

INTRODUCTION

This Chapter explains the operation of the Standard IMU-II/S and the Dual Port IMU-II/S (IMU-II/S with Serial Port Multiplexer option installed). It will instruct the user how the IMU-II/S can be used to communicate with the central computer and the DTE device.

IMU-II/S COMMUNICATIONS

In addition to its pulse collection capabilities, the IMU-II/S can also be used as a communications link between the central computer modem and the DTE device. There are several different ways that this link can be established and maintained. The following sections explain how the link is established using the standard IMU-II/S and the Dual Port IMU-II/S. After the initial connection with the central modem the IMU-II/S will attempt to communicate using Metretek protocol. If the IMU-II/S is unable to establish a Metretek connection within 3 seconds, it will default to a transparent link, simply connecting the central computer to the DTE. In this mode the central computer will have direct control over the DTE via the IMU-II/S.

Communications Parameters

The serial channel communications parameters are programmable by the use of the Metretek Programmer. A byte within the configuration EEPROM is used to hold this information. However, the bit rate of the serial interface will be determined by the bit rate that is being used on telephone line. These parameters must be programmed to match the communications parameters of the DTE device.

The programmable serial channel parameters are the following:

- Number of data bits - 7 or 8 bits
- Number of stop bits - 1, 1.5, or 2 bit(s)
- Parity - odd, even or none

The standard configuration will be 8 data bits, 1 stop bit and no parity.

The maximum modem connect bit rate can also be programmed. This parameter is utilized to limit the bit rate that will be used when connecting with the host modem. For example, if the DTE device is set to communicate at 1200 bits/sec, this parameter should be set to 1200 bits/sec to prevent the IMU-II/S from connecting with the host modem at the default rate of 2400 bits/sec.

When using a Dual Port IMU-II/S these communications parameters must be set for each DTE port.

Standard IMU-II/S Communications

IMU-II/S Call Origination

The IMU-II/S can be triggered to originate a call by two different methods.

1. Auto-dial when a hardware alarm or call-back time occurs.
This method of auto-dial can be used by a DTE device that does not have AT command capability but has a contact closure output. This contact closure output is connected to a IMU-II/S customer alarm input. If the IMU-II/S auto-dials but the alarms are not cleared the IMU-II/S will enter its call retry mode and continue to auto-dial the host until the alarms are cleared. Refer to the section entitled IMU-II/S Alarms - Status Flags for details on the clearing and viewing of alarms.
2. Call origination under AT command control.
The IMU-II/S can be forced by the DTE to originate a call by the use of AT commands. The steps required to originate a call using AT commands is shown in Figure 4-1.
After the IMU-II/S detects that its DTR input has been activated it will wake-up and activate the DSR output. If an AT command string is not received within 20 seconds the IMU-II/S will clear the DSR output and go back to the idle state.

IMU-II/S Answering

The IMU-II/S can be programmed to auto-answer by the Metretek Programmer. The number of rings on which to answer is also programmable. After detecting the appropriate number of ring signals the IMU-II/S will go off-hook and attempt to connect with the originating modem. After the connection, if ASCII alarm download is enabled, the IMU-II/S will transmit its unit ID and any current alarm data to the originating modem. After this information is sent, a transparent link will be made between the IMU-II/S's modem port and the DTE port.

Dual Port IMU-II/S Communications

The Dual Port IMU-II/S consists of the standard IMU-II/S with the optional Serial Port Multiplexer (SPM) installed. The SPM plugs into the IMU-II/S's input terminal block and allows a single IMU-II/S to communicate with two DTE devices via their RS-232 ports. Both DTE serial ports can be individually addressed from the host modem by sending a port select command to the IMU-II/S. The port select command consists of the string "+-+PAXXXXXX" or "+-+paXXXXXX", where the XXXXXX is the Unit ID of the specific port with which the host computer wishes to connect. After receiving this message the IMU-II/S will respond with the message string "CONNECTION WITH PORT XXXXXX NOW TRANSPARENT", where XXXXXX is the Unit ID of port. The port select command may be sent by the central computer to the IMU-II/S at any time after the initial connection is made. The dual port capability must be enabled via the Metretek Programmer.

Dual Port IMU-II/S Call Origination

The IMU-II/S can be triggered to originate a call by two different methods.

1. Auto-dial when a hardware alarm occurs. This method of auto-dial can be used by a DTE device that does not have AT command capability but has a contact closure output. This contact closure output is connected to an IMU-II/S customer alarm input. The Dual Port IMU-II/S has the ability to auto-dial two different phone numbers. The IMU-II/S will auto-dial phone number 1 when any alarm excluding the Input 2 alarm 1 occurs. The IMU-II/S will auto-dial phone number 2 only when a Input 2 alarm is detected. If the IMU-II/S auto-dials but the alarms are not cleared the IMU-II/S will enter its call retry mode and continue to auto-dial the host until the alarms are cleared. Refer to the Alarm Maintenance section of this chapter for details on the clearing and viewing of alarms.
2. Call origination under AT command control. The IMU-II/S can be forced to originate a call by using AT commands. The steps shown in Figure 4-1 must be performed to originate a call. After the IMU-II/S detects that its DTR input has been activated it will wake-up and activate the DSR output on port 1. If an AT command string is not received from port 1 within 2 seconds the IMU-II/S will clear the port 1 DSR and activate the port 2 DSR. The IMU-II/S will then look for an AT command string from port 2. If the command is not received within 2 seconds the IMU-II/S will switch back to port 1 and repeat the process. The IMU-II/S will repeat the initial sequence 5 times in an effort to establish a connection.

Dual Port IMU-II/S Answering

The Dual Port IMU-II/S can be programmed to auto-answer by the Metretek Programmer or via the ATSO command. After answering and connecting with the originating modem the IMU-II/S will wait a programmable timeout period (0 to 30 seconds) for a port select command. If the port select command is not received from the host computer the IMU-II/S will operate according to the programmable port default mode. The port default mode can be programmed to be one of the following:

Port 1 - The IMU-II/S will default to a connection to DTE port 1 after the timeout period expires.

Port 2 - The IMU-II/S will default to a connection to DTE port 2 after the timeout.

Alternate - The default port will alternate between port 1 and port 2 after the timeout.

For Example: 1st Call - IMU-II/S defaults to port 1.

2nd Call - IMU-II/S defaults to port 2.

3rd Call - IMU-II/S defaults to port 1. etc...

None - The IMU-II/S will abort the phone connection if a port is not selected within the timeout period.

The steps that are followed by the Dual Port IMU-II/S when answering are shown in Figure 4-2.

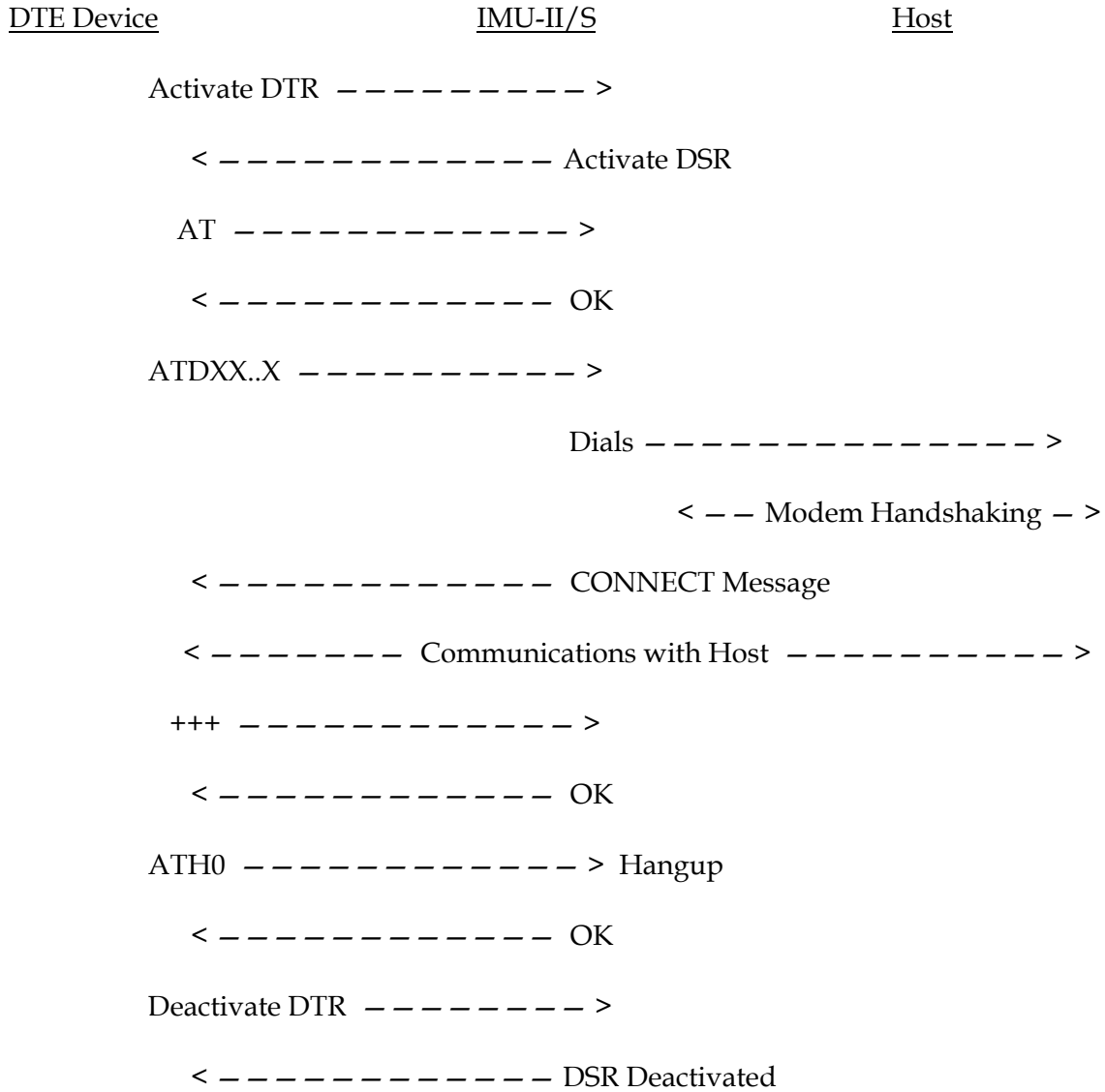

Figure 4-1 AT Command Call Origination

NOTES

1. After the Dual Port IMU-II/S detects that its DTR input has been activated it will wake-up and activate the DSR output on port 1. If an AT command string is not received from port 1 within 2 seconds the IMU-II/S will clear the port 1 DSR and activate the port 2 DSR. The IMU-II/S will then look for an AT command string from port 2. If the command is not received within 2 seconds the IMU-II/S will switch back to port 1 and repeat the process. The IMU-II/S will repeat the initial sequence 5 times in an effort to establish a connection.

2. After DSR is deactivated the Dual Port IMU-II/S will return to a low power idle state.

- During the AT Command Call Origination, the IMU-II/S does not attempt to connect using Metretek protocol but goes immediately to transparent mode.

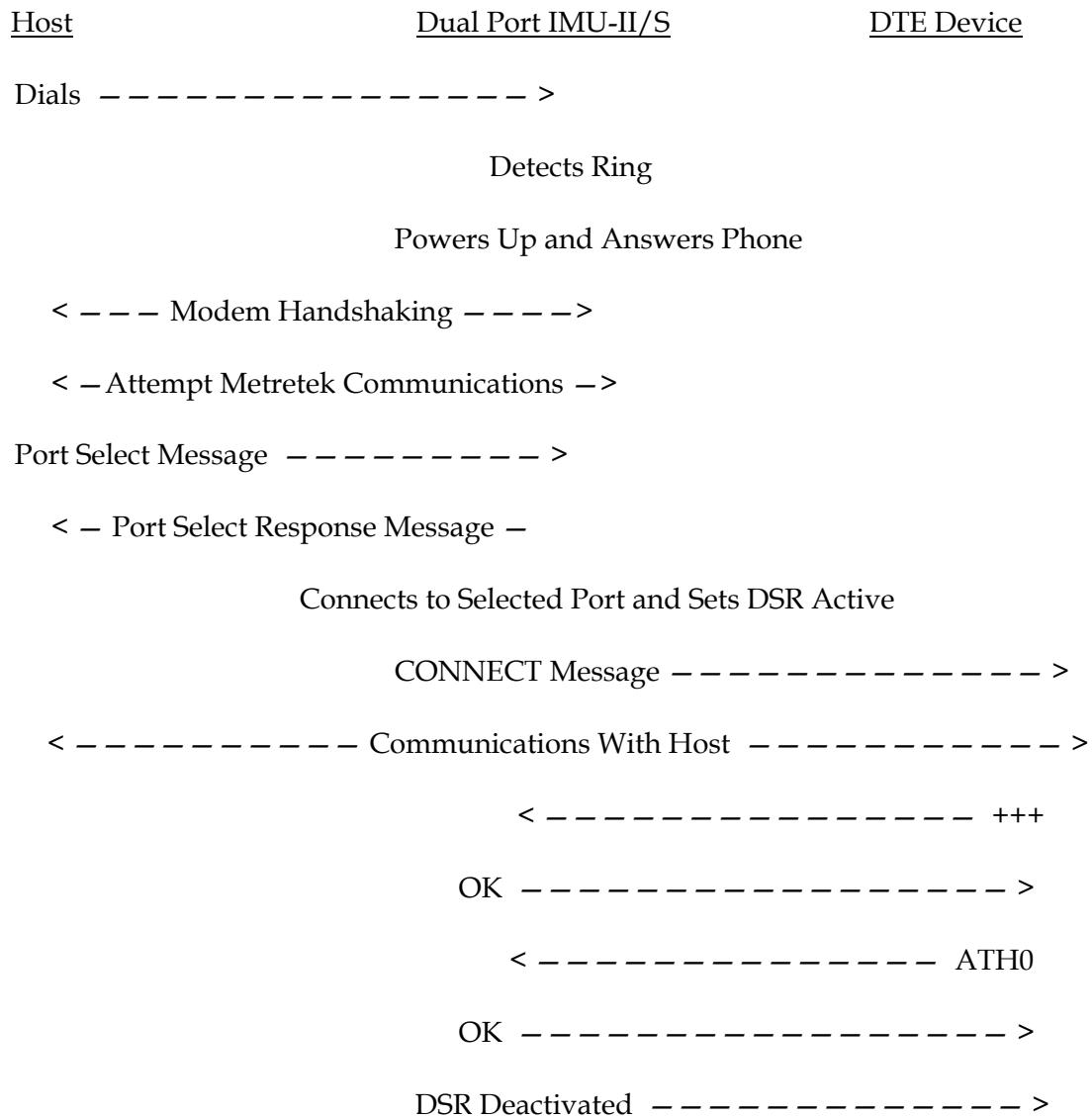

Figure 4-2 Dual Port IMU-II/S Answering

NOTES

- Port select command message: +-PAXXXXXX (X = ASCII hex number, 0-F)
- Port select response message: CONNECTION WITH PORT XXXXXX NOW TRANSPARENT

3. If a port select command message is not received within the programmable timeout period the IMU-II/S will default to a port connection depending on the preprogrammed port default mode.
4. The IMU-II/S will delay 1 second after setting DSR active before sending the CONNECT message.
5. If the Host ends the communications session by disconnecting, the IMU-II/S will send a "NO CARRIER" message to the DTE.

AT COMMAND SET COMPATIBILITY

An IMU-II/S can be controlled by the DTE by the use of the AT commands shown in Table 4-1. The IMU-II/S will respond to the AT commands with the result codes that are shown in Table 4-2.

Table 4-1 IMU-II/S AT Commands

| <u>Command</u> | <u>Function</u> |
|----------------|---|
| AT | Test for OK result code |
| ATH0 | Go on-hook |
| ATH1 | Go off-hook |
| ATE0 | Character echo off |
| ATE1 | Character echo on |
| ATDTXXX...X | Go off-hook, tone dial and connect |
| ATDPXXX...X | Go off-hook, pulse dial and connect |
| | Additional ATD dialing characters |
| | W - Wait for dial tone |
| | , - dialing delay |
| ATV0 | Set result code format to numeric codes |
| ATV1 | Set result code format to verbal codes |
| ATS0=XX | Set number of rings on which to answer (0 - 15), If set to 0 then auto answer is disabled |
| ATS8=XX | Set the delay value of the ATD delay character (,) |
| +++ | Escape to command mode |
| ATO0 | Return to online state |
| AT\$ | Display AT command set |

Table 4-2 IMU-II/S Valid AT Result Codes

| <u>Numeric</u> | <u>Verbal</u> |
|----------------|---------------|
| 0 | OK |
| 1 | CONNECT |
| 2 | RING |
| 3 | NO CARRIER |
| 4 | ERROR |
| 5 | CONNECT 1200 |
| 6 | NO DIAL TONE |
| 7 | BUSY |
| 8 | NO ANSWER |
| 10 | CONNECT 2400 |

IMU-II/S ALARMS - STATUS FLAGS

The IMU-II/S has various alarms and status flags. If the IMU-II/S is enabled to auto-dial, the alarm condition will cause the IMU-II/S to immediately place call to the central computer. Status flags will not trigger a call to the central computer, but they will be reported on the next communications with the central computer. These alarms and status flags are designed to inform the computer that an exception condition exists at the IMU-II/S. If a Metretek protocol connection is established these alarm/status flags will be sent to the host computer using Metretek protocol. If the IMU-II/S fails to connect using Metretek protocol, the IMU-II/S will default to the transparent mode and the alarms and status flags will be sent to the central modem as an ASCII string at the beginning of communications. Preceding these alarm strings the IMU-II/S will transmit its unit identification number using the format listed below.

UID# NNNNNN

This unit ID number is read from the IMU-II/S's configuration memory and is programmed by the Metretek Programmer.

If the IMU-II/S is enabled for dual port operation it will call phone number 1 when all alarms except customer alarm 2 occurs. A customer alarm 2 occurrence will cause the IMU-II/S to call phone number 2. If the IMU-II/S is calling phone number 1 it will report Port 1 Unit ID. If the IMU-II/S is calling phone number 2 it will report Port 2 Unit ID.

If the IMU-II/S is not enabled to auto-dial the active alarms will be reported at the next scheduled communication with the central computer.

Table 4-3 shows the ASCII string that is transmitted for each specific IMU-II/S status/alarm flag when in transparent mode. The alarm strings that are transmitted when a customer alarm 1 or customer alarm 2 occurs are programmable via the programming port by using a laptop PC and the Metretek Programmer software. These programmable alarm strings can be up to 20 characters in length.

TRANSPARENT MODE ALARM MAINTENANCE COMMANDS

The alarms reported in transparent mode must be cleared by the central computer by transmitting the ASCII string "+-+clralms" to the IMU-II/S. The alarms can also be cleared by sending the IMU-II/S the string "+-+ca" or "+-+CA". The IMU-II/S will respond with an "OK" message after the flags have been cleared. If the IMU-II/S is enabled for auto-dial and an alarm occurs the clear alarm string must be sent to the IMU-II/S to acknowledge the receipt of the alarm. If the call is aborted and the alarm has not been cleared the unit will enter the call retry mode and call back at the programmed call retry interval. The IMU-II/S will remain in the call retry mode until it receives the clear alarm string from the central computer.

After connection with the IMU-II/S and the initial transmission of the alarms, the central computer may request that the alarms be retransmitted by sending the scan alarms command ("+-+SA" or "+-+ sa") to the IMU-II/S. The IMU-II/S will respond by retransmitting the unit ID and alarm messages.

Table 4-3 IMU-II/S Status Flags

| ALARM | ASCII STRING | DESCRIPTION |
|----------------------------------|--------------------------------------|--|
| LOW BATTERY | *LOW BATTERY ALARM* (*see note 2) | The IMU-II/S's battery is nearing a discharged condition and the battery needs replacement. The IMU-II/S checks its battery voltage level at the beginning and end of each call. |
| CALL RETRY | *CALL RETRY ALARM* | The IMU-II/S's previous call was unsuccessful. (A call is attempted again at the primary retry rate for the number of times specified for a primary retry in the IMU-II/S's configuration EEPROM. Then, calls are placed at the secondary retry rate specified in the IMU-II/S's configuration EEPROM until the call is successful.) |
| UNIT RESET | *UNIT RESET ALARM* | The IMU-II/S module is forced to restart because it's being installed or a program interruption has been detected. |
| INPUT 1 ALARM (see Note 1) | *CUSTOMER ALARM 1* | Normally open Customer-specified alarm, activated by closing the circuit. (TB1-3 to TB1-5) |
| INPUT 2 ALARM (see Note 1) | *CUSTOMER ALARM 2* | Normally open Customer-specified alarm, activated by closing the circuit. (TB1-4 to TB1-5) |
| TAMPER ALARM | *TAMPER ALARM* | The normally closed tamper alarm indicates that the tamper circuit has been activated. (A door switch that is normally closed has opened.) |
| CUSTOMER ALARM | *CUSTOMER ALARM* | Normally open alarm input. Activated by closing the circuit. (TB1-1 to TB1-2) |
| AC OFF | *AC OFF ALARM* | AC power to the IMU-II/S has been off for 5 minutes. |
| AC ON | *AC ON ALARM* | AC power to the IMU-II/S has returned and has been on for 5 minutes. |

Note 1: The ASCII alarm strings that are reported for Input 1 Alarm and Input 2 Alarm are programmable using the Metretek Programmer.

Note 2: Due to battery voltage fluctuations over temperature and load, we recommend that the IMU-II/S's battery not be changed until the IMU-II/S has reported a low battery alarm for 7 consecutive days.

NOTES

CHAPTER FIVE: ON-SITE TROUBLESHOOTING

INTRODUCTION

This chapter explains the troubleshooting steps you should try before contacting Metretek's Customer Service Department.

WARNING

Do not disconnect or connect live circuits unless area is known to be nonhazardous.

GENERAL TROUBLESHOOTING

If the IMU-II/S does not call, does not answer or does not connect with the central modem, perform the following procedures:

Check for the Telephone Line Dial Tone

1. Unplug the telephone cable from J1 on the IMU-II/S board. For the exact location of J1, refer to Figure 5-1.
2. Connect the telephone test set to the telephone company line.
3. Go offhook and listen for a dial tone.

If a dial tone is not heard, a problem exists with the telephone line. Contact your local telephone company in order to have the phone line repaired.

If a dial tone is heard, a problem exists elsewhere in the system.

4. Plug the telephone cable back into the IMU-II/S.

Check Battery Voltage

1. Close and open the IMU-II/S enclosure. The IMU-II/S enclosure must be closed for a minimum of 2 seconds. This will cause the IMU-II/S to detect a tamper alarm and switch to the high power mode.
2. Connect a digital voltmeter to the empty battery connector, J3 or J4.
3. Verify that the battery voltage is as follows:

Lithium Battery Pack - greater than 3.1 Vdc

If the battery reading is lower than the required voltage, follow the direction in Chapter Six to replace the battery.

If the battery level is acceptable, reset the IMU-II/S by following the directions below.

Reset the IMU-II/S

Reset the IMU-II/S by momentarily shorting the RESET jumper JP4. If the unit is enabled for auto-dial and a phone number has been programmed into the IMU-II/S, the unit should go off-hook and attempt to call the central computer in approximately 10 to 15 seconds. If the unit still will not function properly, refer to Chapter 7, Return Equipment Procedure, for instructions to return your equipment.

Immediately after the reset, the IMU-II/S will turn the green FIRMWARE MONITOR LED on solid while it runs its RAM test. If the RAM test fails, the FIRMWARE MONITOR and OFFHOOK LEDs will be turned off and all other LEDs will be turned on. If the test is successful, the IMU-II/S will momentarily light the RD LED. The FIRMWARE MONITOR LED will then begin to blink.

NOTE

Whenever the IMU-II/S detects a TAMPER alarm (enclosure door open), the LEDs will be activated for 4-1/4 minutes. To re-enable the LEDs after the 4-1/2 minute period has expired, close and reopen the IMU-II/S enclosure.

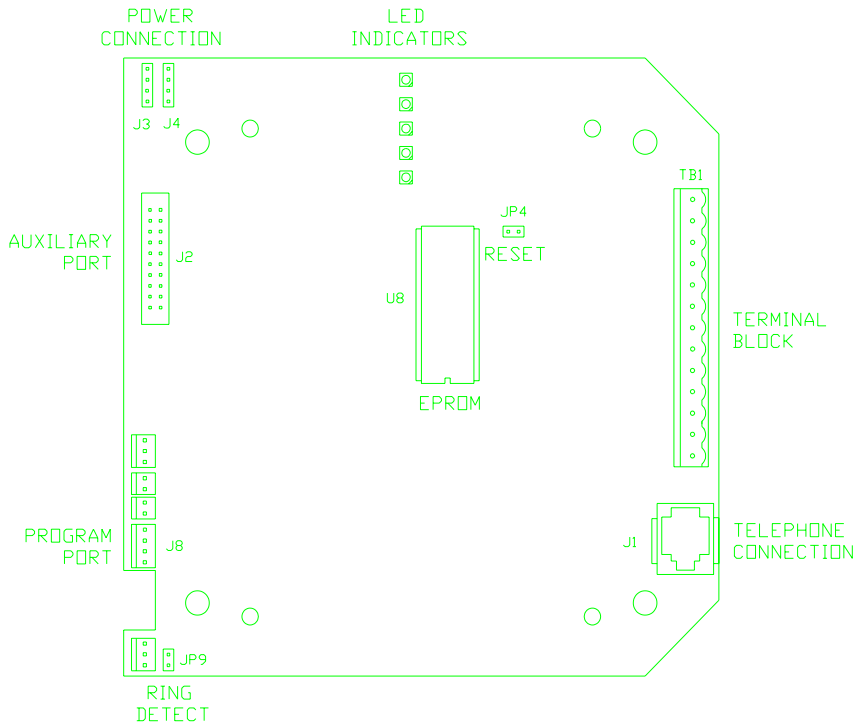

Figure 5-1. IMU-II/S Board

ADDITIONAL AUTO-ANSWER TROUBLESHOOTING

If the unit will not properly auto-answer, perform the following steps:

1. Verify that the ring detect jumper, JP9, is in place.
2. Verify that the IMU-II/S has been programmed to answer on the correct number of rings with the Metretek Programmer software, the serial programming cable and a PC. See the list of materials for part numbers.

ADDITIONAL AUTO-DIALING TROUBLESHOOTING

If the unit goes off-hook but does not connect with the central modem perform the following steps:

1. Verify that the correct phone numbers have programmed into the IMU-II/S with the Metretek Programmer.
2. Verify that the IMU-II/S has been configured for auto-dialing with the Metretek Programmer software.

3. Call the central computer operator and verify that the central modem is on-line and ready to receive calls.

NO COMMUNICATION WITH DTE

If the Central Computer is not able to communicate with the Electronic corrector, perform the following steps:

1. Verify that the IMU-II/S serial port is correctly connected to the DTE as outlined in Chapter 3.
2. Verify that the communications parameters (parity, number of data bits, number of stop bits) are correctly programmed for the serial interface with the Metretek Programmer software, the serial programming cable, and a PC. The communications parameters of the IMU-II/S must match the communication parameters of the DTE device.
3. Verify that the DTE serial port has been configured for the correct number of data bits, number of stop bits, and parity. The bit rate of the DTE serial port must match the bit rate of the central computer; either 300, 1200, or 2400.

NOTE

When the IMU-II/S is operating in the transparent mode, the bit rate of the IMU-II/S will be determined by the bit rate of the modem to which it makes a connection. For example, if the IMU-II/S is called by a V.22 bis 2400 bits/sec modem, the IMU-II/S will switch its data rate to 2400 bits/sec on its serial interface and on its modem interface.

CHAPTER SIX: MAINTENANCE

INTRODUCTION

Your Metretek IMU-II/S will operate with very little maintenance. This chapter is to inform you of the parts of your Metretek equipment which should be maintained.

BATTERY

The IMU-II/S operates on a lithium battery pack. Replace the battery when a low battery alarm has occurred for 7 consecutive days. The IMU-II/S's battery life is dependent on the frequency of the calls, the length of each call and the operating temperature.

| TYPE | BATTERY LIFE | *BATTERY REPLACEMENT |
|---------------------------------------|---------------|----------------------|
| IMU-II/S with one Lithium "D" battery | 2.5 - 5 years | approx. 3 months |

NOTE

1. **Battery Replacement - remaining battery life after receiving a low battery alarm.**
2. **Due to battery voltage fluctuations over temperature and loads, we recommend that the IMU-II/S's battery not be changed until the IMU-II/S has reported a low battery alarm for 7 consecutive days.**

Lithium Battery Replacement

1. Plug the replacement lithium battery pack onto the spare battery connector (J3 or J4).
2. Unplug the discharged lithium battery pack and remove it from the battery holder.
3. Place the replacement lithium battery pack into the holder, and secure it with the tie wraps.

WARNING

Do not disconnect or connect the batteries unless area is known to be nonhazardous.

NOTES

CHAPTER SEVEN: RETURN EQUIPMENT PROCEDURE

INTRODUCTION

If you should encounter a problem with the IMU-II/S, this chapter explains the procedure to return equipment to Metretek.

RETURN EQUIPMENT PROCEDURE

In order to return any equipment to Metretek, please contact Metretek's Customer Service Department at 1-800-327-8559 and obtain a return authorization (RA) number. Complete the checklist contained on the next page. Detach and return the checklist with the malfunctioning equipment to Metretek by your company's standard procedures.

IMU-II/S FAILURE CHECKLIST

Customer:

RA No.:

AIS No.:

Serial No.:

Reported By:

Date IMU-II/S Removed:

Location:

Last Call Date and Time:

Please circle the number (and/or item) why the unit failed:

1. Communications unsuccessful at any stage of call procedure.

Unit will not dial.

Unit will dial, but no data is transmitted or received.

Unit will not answer.

2. Unit calls excessively. State the alarms that caused unit to have excessive calls:

3. Other (please be specific):

Visual Inspection:

Please enclose this checklist with the IMU-II/S being returned to:

Metretek, Incorporated
300 North Drive
Melbourne, FL 32934

APPENDIX A: PRODUCT SPECIFICATIONS

| <u>Parameter</u> | <u>Specification</u> |
|--|--|
| Operating Temperature Range | -30 to +70 C |
| Enclosure Specifications | |
| Height | 6.5 inches (16.5 cm) |
| Width | 6.9 inches (17.5 cm) |
| Depth | 4.3 inches (10.9 cm) |
| Weight, Lithium Battery Power | 2.5lb / 1.10Kg (including lithium battery). |
| Power Supply | |
| Battery Powered | Lithium battery, 3.6VDC, 11.5 Ahr. |
| Typical Battery Life | |
| Battery Powered | 3 years nominal. Battery life is dependent on number and state of pulse/alarm inputs, number of calls and temperature. |
| Telephone Interface Specifications: | |
| Ringer Equivalence | 0.3 B |
| FCC Registration Number | BK5USA-24666-DT-E |
| Pulse Dialing Mode: | |
| Dial Rate | 10 pulses / second |
| Percent Break | 60% |
| Interdigit Interval | 800ms |
| Dialing Digits | 31 (maximum) |
| DTMF Dialing Mode: | |
| Deviation from standard tone | 0.73% maximum |
| Dial Rate | 3.3 digits / second |
| Interdigit Interval | 150ms |
| Output Level | -6dBm (nominal) |

Telephone Interface Specifications continued:

| | |
|----------------|--------------|
| Dialing Digits | 31 (maximum) |
| Pause Mode | Programmable |

Communication Signals:

| | |
|-----------------------|---|
| Modulation Standards | CCITT V.22bis (2400 bps) CCITT V.22 (1200 bps) Bell 212A (1200 bps) Bell 103 (300 bps) |
| Data Output Level | Less than -9dBm (fixed) |
| Modem Sensitivity | -40dBm (minimum) |
| Telephone Connector | 4-conductor RJ-11C |
| Data Storage Capacity | 32K RAM (»28K for Time Tagged Intervals) |

Customer Inputs:

Serial Inputs:

| | |
|-----------|------------------------|
| Type | RS-232C |
| Baud Rate | 300, 1200, or 2400 bps |
| Data Bits | 7 or 8 |
| Stop Bits | 1, 1.5, or 2 |
| Parity | Even, Odd, or None |

Contact Closure Inputs:

| | |
|--------------|--|
| Tamper Alarm | Form-B (normally closed, transition to open triggers alarm) TB1-6, TB1-7 |
| Data Input 1 | Form-A (normally open, transition to closed causes a pulse to be recorded or an alarm to be triggered). TB1-3, TB1-5 |
| Data Input 2 | Form-A (normally open, transition to closed causes a pulse to be recorded or an alarm to be triggered). TB1-4, TB1-5 |
| Alarm Input | Form-A (normally open, transition to closed, causes an alarm to be triggered). TB1-1, TB1-2 |

| | |
|-----------------------------------|---|
| Maximum Voltage Drop / Resistance | 0.8VDC maximum, 1000 ohms maximum (switch + cable, switch on) |
| Active State | Must be active for greater than 40ms. (Inputs must be inactive for 40 msec minimum before new pulse can be detected.) |
| Data Input Rate | 600 counts / minute maximum |
| Wetting Voltage per Input | 3 to 5 volts (nominal) |
| Wetting Current per Input | 175uA (nominal) |

APPENDIX B: TII STATION PROTECTOR

INDEX

A

Abbreviated terms 1-6
AC Powered IMU-II/S 3-10
American wire gauge 1-6
AWG 1-6

B

Battery
Connectors 6-1
Install lithium battery 3-10
Maintenance 6-1
Passivation layer 2-5, 6-2
Resistor 2-5, 6-2
Battery replacement
Lithium 6-1
Bushing 3-3

C

Cables, install
Alarm cables 3-5
Grounding cable 3-4

D

Dual Port IMU-II/S 1-1

E

Equipment setup 2-4

F

FCC-required notifications 1-4

G

Grounding cable, attach 3-3

I

IMU-II/S 1-2
IMU-II/S layout 2-1, 2-2
IMU-II/S Operations 4-1
Industrial Metering Unit Model II/S 1-2
Install cables 3-3

L

LED 1-6
LED Functions 3-14
Light emitting diode 1-6
List of materials
Provided by customer 2-3
Provided by Metretek 2-3
Purchased from Metretek 2-3
List of tools 2-4
Lithium batteries 3-10

M

Magnetic switch 3-13
Maintenance, battery 6-1
Materials 2-1
Metretek programmer software 2-3
Mount equipment 3-2
Mounting dimensions 3-2

P

Power Source, install
AC Power 3-10
Lithium Battery 3-10
Passivation layer 2-5, 6-2
Program IMU-II/S 3-11

R

Reference documents
CDOC notifications 1-2
FCC-required notification 1-4
Warranty information 1-2
Return authorization (RA) number 6-1
Return equipment procedure 6-1

S

Serial Data Connection 3-8
Serial Port Multiplexer Connection 3-9
Setup of equipment 2-4
Storage of batteries 2-5

T

Terminal strip, IMU-II/S 3-6
TII telephone station protector
Earth ground 3-3
Telephone cables 3-3
Wiring 3-3
Tools 2-4
Troubleshooting
Battery voltage, check 5-1
Telephone cable 5-1

W

Warranty information 1-3

NOTES