

INDUSTRIAL METERING UNIT (IMU-II/s) INSTALLATION MANUAL

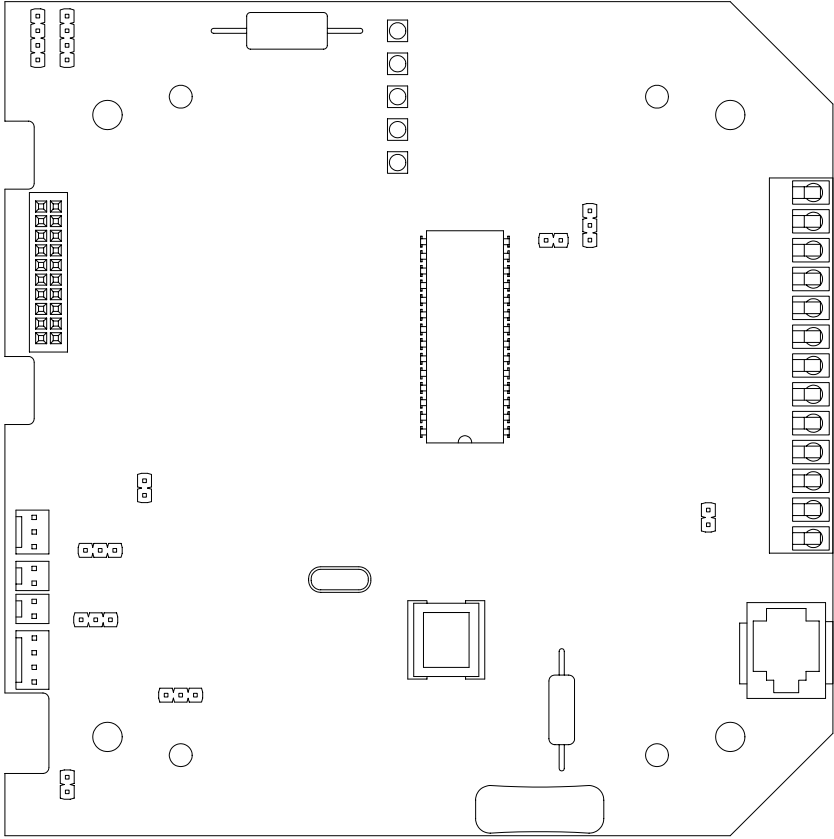

COPYRIGHT © 2006 by Metretek, Incorporated

All rights to this document, domestic and international, are reserved by Metretek, Incorporated. No part of this publication may be reproduced, stored in a retrieval system, or transmitted in any form or by any means (electronic, mechanical, photocopying, recording, or otherwise) without the prior written permission of Metretek, Incorporated. Requests for permission to reproduce or distribute this manual should be addressed to:

PUBLICATIONS DEPARTMENT
METRETEK, INCORPORATED
305A EAST DRIVE
MELBOURNE, FL (USA) 32904

The trademark AIS ® is registered (with the) United States Patent and Trademark Office.

Table of Contents

CHAPTER ONE: INTRODUCTION TO THE MANUAL	1-1
PRODUCT DESCRIPTION.....	1-1
Industrial Metering Unit Model II / Serial	1-1
Dual Port IMU-II/S.....	1-1
WARRANTY INFORMATION	1-2
TELECOM AND SAFETY NOTIFICATIONS	1-3
IMPORTANT SAFETY INSTRUCTIONS.....	1-4
SCOPE OF MANUAL	1-5
Chapter One: Introduction to the Manual.....	1-5
Chapter Two: Pre-Installation	1-5
Chapter Three: Installation of the IMU-II/S	1-5
Chapter Four: IMU-II/S Operation.....	1-5
Chapter Five: On-Site Troubleshooting	1-5
Chapter Six: Maintenance.....	1-5
Chapter Seven: Return Equipment Procedure	1-5
CHAPTER TWO: PRE-INSTALLATION	2-1
INTRODUCTION	2-1
LIST OF MATERIALS	2-1
Materials Provided by Metretek	2-2
Materials Purchased from Metretek	2-2
Materials Provided by Customer.....	2-2
LIST OF TOOLS	2-3
EQUIPMENT SETUP.....	2-3
OBTAIN A LIST CONTAINING SITE INFORMATION.....	2-3
VERIFY TELEPHONE LINE INSTALLATION.....	2-3
HAZARDOUS AREA INSTALLATION	2-4
CHAPTER THREE: INSTALLATION OF THE IMU-II/S	3-1

INTRODUCTION	3-1
MOUNT EQUIPMENT	3-2
INSTALL CABLES	3-3
Telephone Line Station Protector Installation	3-3
Attach Input Cables.....	3-5
Serial Data Connection	3-8
Serial Port Multiplexer Connection.....	3-9
VERIFY RING DETECT JUMPER.....	3-9
INSTALL POWER SOURCE	3-10
Lithium Batteries	3-10
VERIFY POWER UP	3-11
PROGRAM IMU-II/S	3-11
VERIFY OPERATION OF IMU-II/S.....	3-11
Verifying Auto-Answer	3-11
Verify Auto-Dial Operation	3-13
CLOSE THE IMU-II/S	3-13
CHAPTER FOUR: IMU-II/S OPERATIONS	4-1
INTRODUCTION	4-1
IMU-II/S COMMUNICATIONS	4-1
Communications Parameters.....	4-1
Standard IMU-II/S Communications	4-2
Dual Port IMU-II/S Communications	4-2
AT Command Set Compatibility.....	4-6
IMU-II/S ALARMS - STATUS FLAGS.....	4-7
TRANSPARENT MODE ALARM MAINTENANCE COMMANDS	4-7
CHAPTER FIVE: ON-SITE TROUBLESHOOTING	5-1
INTRODUCTION	5-1
GENERAL TROUBLESHOOTING.....	5-1
Check for the Telephone Line Dial Tone	5-1

Check Battery Voltage	5-1
Reset the IMU-II/S	5-2
ADDITIONAL AUTO-ANSWER TROUBLESHOOTING	5-4
ADDITIONAL AUTO-DIALING TROUBLESHOOTING.....	5-4
NO COMMUNICATION WITH DTE	5-4
NO COMMUNICATION WITH MERCURY INSTRUMENTS ECAT	5-6
NO COMMUNICATION WITH THE INLINE CORRECTOR	5-6
CHAPTER SIX: MAINTENANCE.....	6-1
INTRODUCTION	6-1
BATTERY	6-1
Lithium Battery Replacement.....	6-1
CHAPTER SEVEN: RETURN EQUIPMENT PROCEDURE.....	7-1
INTRODUCTION	7-1
RETURN EQUIPMENT PROCEDURE.....	7-1
APPENDIX A: PRODUCT SPECIFICATIONS.....	A-1
Telephone Interface Specifications.....	A-2
APPENDIX B: TII STATION PROTECTOR	B-1
INDEX.....	I-1

List of Illustrations

Figure 2-1 Lithium Battery Powered IMU-II/S	2-1
Figure 2-2 Optional Serial Port Multiplexer	2-2
Figure 3-1 IMU-II/S Mounting Dimensions.....	3-2
Figure 3-2 Bushings.....	3-3
Figure 3-3 Wiring of the Surge Protector	3-4
Figure 3-4 IMU-II/S Terminal Strip.....	3-6
Figure 3-5 IMU-II/S Serial Port Multiplexer Terminal Strip.....	3-6
Figure 3-6 IMU-II/S Input Connections	3-7
Figure 3-7 IMU-II/S Board.....	3-8
Figure 3-8 Lithium Battery Powered IMU-II/S	3-10
Figure 4-1 AT Command Call Origination.....	4-4
Figure 4-2 Dual Port IMU-II/S Answering	4-5
Figure 5-1 IMU-II/S Board.....	5-3

List of Tables

Table 3-1 LED Functions	3-14
Table 4-1 IMU-II/S AT Commands	4-6
Table 4-2 IMU-II/S Valid AT Result Codes	4-6
Table 4-3 IMU-II/S Status Flags	4-8

CHAPTER ONE: INTRODUCTION TO THE MANUAL

PRODUCT DESCRIPTION

Industrial Metering Unit Model II/Serial

The Industrial Metering Unit Model II/Serial (IMU-II/S) is the remote solid state recorder part of a reliable automatic data collection system. The IMU-II/S is designed to collect pulse data from up to two inputs and store the data as a function of time (time-tagged interval data). The pulse data detected on these two inputs is also stored in an accumulator register and can be used to track a meter index. The IMU-II/S has 32K bytes of RAM which allows the unit to gather 15 minute data from two inputs for 70 days. The IMU-II/S will attempt to call the central computer when its memory is 75% full (52.5 days) so that no data will be overwritten and lost. This information is stored at the central computer where it is available for analysis and display.

At a preprogrammed time or when an alarm is detected, the IMU-II/S dials the central computer and transfers the collected information plus any alarm data via standard telephone lines. If the IMU-II/S is unable to successfully complete the call it will go into its predetermined call retry mode and attempt to communicate the data to the host computer at a later time.

The IMU-II/S can also be used as a modem to remotely access field data collection devices (Data Terminal Equipment (DTE) such as electronic correctors, flow computers, etc.) that have a RS-232 channel. The IMU-II/S is capable of communicating at rates of 300, 1200, and 2400 bits/sec.

The IMU-II/S can also be controlled by the DTE device using AT compatible commands. The DTE can awaken the IMU-II/S using the DTR control line and then use AT commands to force the IMU-II/S to dial and connect with a host modem.

For further information on the IMU-II/S's capabilities, please refer to Chapter 4 entitled "IMU-II/S Operation".

Dual Port IMU-II/S

The Dual Port IMU-II/S consists of the standard IMU-II/S with the optional Serial Port Multiplexer (SPM) installed. The SPM plugs into the IMU-II/S's input terminal block and allows a single IMU-II/S to communicate with two DTE devices via their RS-232 ports. Both the DTE serial ports can be individually addressed from the host modem by sending a port select command to the IMU-II/S. The dual port capability must be enabled in the IMU-II/S via the Metretek Programmer.

WARRANTY INFORMATION

The seller warrants its hardware to be free from defects in material and workmanship under normal and proper use for a period of 12 months from the date the hardware is shipped from Metrotek, Incorporated. The seller's sole liability and the buyer's sole remedy for any breach of the foregoing provision is, at the seller's option, the timely no-charge repair or replacement of any defective hardware or part that Metrotek inspects and finds reasonable evidence that a defect in material or workmanship exists. The buyer shall provide the labor required to remove the defective hardware and install its replacement at no charge to the seller. The equipment will be shipped to the seller at the buyer's expense. The replacement or repaired equipment will be shipped to the buyer at the seller's expense.

Warranty claims to be honored under this warranty must be made promptly. Such claims shall specify the nature and details of the claim, the date that the cause of the claim was first observed, and the affected equipment's unit serial number. Defective equipment shall not be returned to the seller's factory without prior authorization from the seller. A copy of the claim's documentation must be attached to the defective equipment and sent to the seller's manufacturing facility. Defective components replaced under this warranty shall become the property of the seller.

The seller makes no representation or warranty other than those set forth in this agreement. THE WARRANTY STATED HEREIN IS EXPRESSLY IN LIEU OF ALL WARRANTIES, EXPRESSED OR IMPLIED, INCLUDING BUT NOT LIMITED TO, ANY EXPRESSED OR IMPLIED WARRANTY OF MERCHANTABILITY OR FITNESS FOR A PARTICULAR PURPOSE. SUCH WARRANTY CONSTITUTES THE ONLY WARRANTY MADE BY THE SELLER WITH RESPECT TO THIS AGREEMENT, THE EQUIPMENT UNITS, OR THE SERVICES TO BE SUPPLIED HEREBY. THE SELLER SHALL NOT BE LIABLE FOR ANY INCIDENTAL OR CONSEQUENTIAL DAMAGES OF ANY KIND.

This warranty will not extend to equipment subjected to accident, to misuse, or to alterations/repair not made and documented in writing by Metrotek.

TELECOM AND SAFETY NOTIFICATIONS

Telecom

The REN is used to determine the quantity of devices, which may be connected to the telephone line. Excessive RENs on the telephone line may result in the devices not ringing in response to an incoming call. In most areas, the number of RENs should not exceed five (5.0). To determine the number of RENs that may be connected to the line in a calling area - (maximum REN) - contact the telephone company.

This equipment uses the following USOC jacks: RJ11C

Modems connected to the Australian telecommunications network must be operated in accordance with the Labeling Notice. This modem has been specifically configured to ensure compliance with the ACA Standards. Do not adjust your modem or software outside the values indicated below. To do so would result in your modem being operated in a non-compliant manner.

Answering Delay:

This equipment is not to be programmed to answer an incoming call in less than 2 seconds from the receipt of ringing.

Decadic Dialing:

This equipment shall not use the decadic / pulse dialing feature.

Call Attempts / Retries:

No more than 15 total attempts are to be made to establish a connection to a given number, and no less than 5 seconds offline be provided between each call attempt.

Failure to set the modem, and any application software used with the modem, to the values shown above will result in the modem being operated in a non-compliant manner. Consequently, this would be in violation of the Labeling Notice for this equipment, and the Telecommunications Act 1997 prescribes penalties for the connection of non-compliant equipment.

The telephone company may make changes in its facilities, equipment, operations, or procedures that could affect the operation of the equipment. If this happens, the telephone company will provide advance notice in order for you to make the necessary modifications in order to maintain uninterrupted service. If trouble is experienced with this equipment, please contact Metretek Technical Support at (800) 327-8559 for repair and warranty information. If the trouble is causing harm to the telephone network, the telephone company may ask you to remove the equipment from the network until the problem is resolved.

It is recommended that the customer install an AC surge arrestor in the AC outlet to which this device is connected. This is to avoid damaging the equipment caused by local lightning strikes and other electrical surges.

IMPORTANT SAFETY INSTRUCTIONS

When using the Metretek model IMU-II/s equipment, basic safety precautions should always be followed to reduce the risk of fire, electric shock and injury to persons, including the following:

1. Read and understand all instructions.
2. Follow all warnings and instructions marked on the product.
3. This product should be operated only from the type of power source indicated on the marking label.
4. The unit shall be installed, serviced, and operated by service personnel only, and the unit shall be located in an area which is accessible to service personnel only.

SCOPE OF MANUAL

This manual is divided into six chapters. Listed below is a brief description of each chapter.

Chapter One: Introduction to the Manual

This chapter explains the purpose of this manual and summarizes each chapter. In addition, a list of abbreviated terms and reference documents that are used within this manual are given.

Chapter Two: Pre-Installation

This chapter provides installation instructions that must be completed before installing the IMU-II/S in the field. A list of materials and tools are also provided.

Chapter Three: Installation of the IMU-II/S

This chapter provides installation instructions for the IMU-II/S in the field. It will discuss how to install the battery, the cables, and how to program the IMU-II/S.

Chapter Four: IMU-II/S Operation

This chapter describes the operation of the IMU-II/S and how it can be used to facilitate communications between the host computer and a DTE device.

Chapter Five: On-Site Troubleshooting

This chapter provides steps to follow when troubleshooting a IMU-II/S.

Chapter Six: Maintenance

This chapter provides maintenance directions for the IMU-II/S.

Chapter Seven: Return Equipment Procedure

This chapter provides steps to return your equipment to Metretek.

NOTES

CHAPTER TWO: PRE-INSTALLATION

INTRODUCTION

This chapter explains how to verify the equipment necessary for the installation and the pre-installation setup of the IMU-II/S. Please review this section before going to the field.

LIST OF MATERIALS

This section lists the materials which are provided by Metretek and the materials which you must provide before you install your IMU-II/S in the field. Figure 2-1 illustrates the lithium battery powered IMU-II/S, and Figure 2-2 illustrates the optional Serial Port Multiplexer.

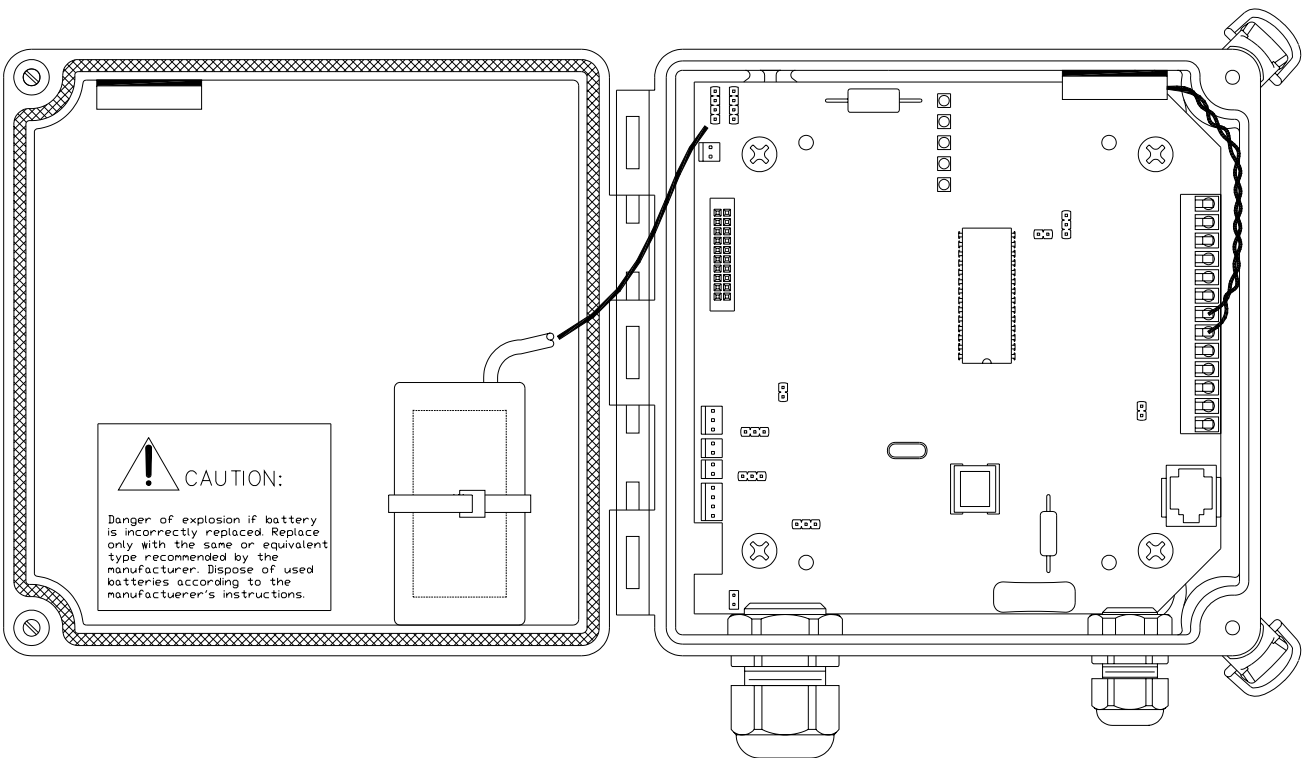

Figure 2-1. Lithium Battery IMU-II/S

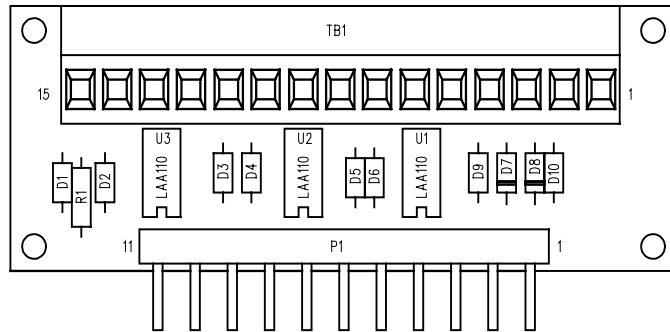

Figure 2-2. Optional Serial Port Multiplexer

NOTE

WHEN USING THE SERIAL PORT MULTIPLEXER, THE BOARD SHOULD BE PLUGGED INTO TERMINAL POSITIONS 3 THROUGH 13 ON THE IMU-II/S BOARD.

Before leaving for the field, you should verify that you have all of the materials listed below:

Materials Provided by Metretek

1. Metretek IMU-II/S.
2. Two enclosure bushings for wire access.
3. Metretek Lithium Battery Pack Stock No. 1011-0022B-001.
4. TII telephone line station protector.

Materials Purchased from Metretek

1. One copy of Metretek Programmer Software (Used with a laptop PC and a Metretek Serial Interface Cable to program/configure the IMU-II/S) with users manual 900203.
2. One Metretek Serial Interface Cable - Metretek Stock No. 1002-0151C-001.

Materials Provided by Customer

1. Cables

- For connecting earth ground to the TII telephone line station protector.
Recommend: Insulated, No. 12 AWG solid copper, green wire.
- For connecting the IMU-II/S to the TII telephone line station protector and the telephone network interface.
Recommend: 24 AWG, 4 connector solid phone cable (Carol P/N C4424).
RJII telephone plugs (KYCON P/N MP 64R-5000S).

- For connecting the IMU-II/S to the DTE's serial port.
Recommend: 3 conductor insulated shielded cable, stranded, 20 AWG, Alpha P/N 35463 or
4 conductor insulated shielded cable, stranded, 20 AWG , Alpha P/N 35464 .
- For connecting alarm switches to IMU-II/S alarm inputs and 8 VAC to IMU-II/S AC power board.
Recommend: 2 conductor insulated cable, stranded, 20 AWG, Alpha P/N 1172.

2. One IBM PC compatible laptop computer with a standard RS-232 serial port.
Note: For programming/configuration of IMU-II/S.

LIST OF TOOLS

1. A 1/8 inch flat-blade screwdriver for terminal strip.
2. A handheld digital voltmeter.
3. A telephone test set.
4. Wire strippers and cutters capable of stripping a 12-24 AWG wire.
5. RJ-11 plug installation tool - AMP Incorporated Part No. 1-231652-0.

EQUIPMENT SETUP

Before going to the field to install your equipment, you should complete two steps:

1. Obtain a list containing site information.
2. Verify telephone line installation.

OBTAIN A LIST CONTAINING SITE INFORMATION

A list containing the following information will be useful for each IMU-II/S you are installing in the field:

- Phone number of the central computer (If the unit will be enabled to auto-dial).
- Customer's address/meter location.
- The IMU-II/S's enclosure serial number.
- Utility's account billing number.

VERIFY TELEPHONE LINE INSTALLATION

Before leaving to install the IMU-II/S, verify that the telephone line has been installed at each site where you are placing an IMU-II/S.

CAUTION

This unit does not work on digital phone systems. Connection to a digital phone system could damage the unit.

HAZARDOUS AREA INSTALLATION

The IMU-II/S is not classified as being intrinsically safe. If the IMU-II/S is to monitor gas consumption in a hazardous area, follow your company's policy for hazardous location installations.

CHAPTER THREE: INSTALLATION OF THE IMU-II/S

INTRODUCTION

This chapter explains how to install the IMU-II/S in the field. Refer to Appendix B for the IMU-II/S specifications.

WARNING

- Never install telephone wiring during a lightning storm.
- Never install telephone jacks in wet locations unless the jack is specifically designed for wet locations.
- Never touch uninsulated telephone wires or terminals unless the telephone line has been disconnected at the network interface.
- Use caution when installing or modifying telephone lines.

MOUNT EQUIPMENT

Attach the IMU-II/S to a wall or pipe from the meter. Figure 3-1 shows the dimensions of the IMU-II/S.

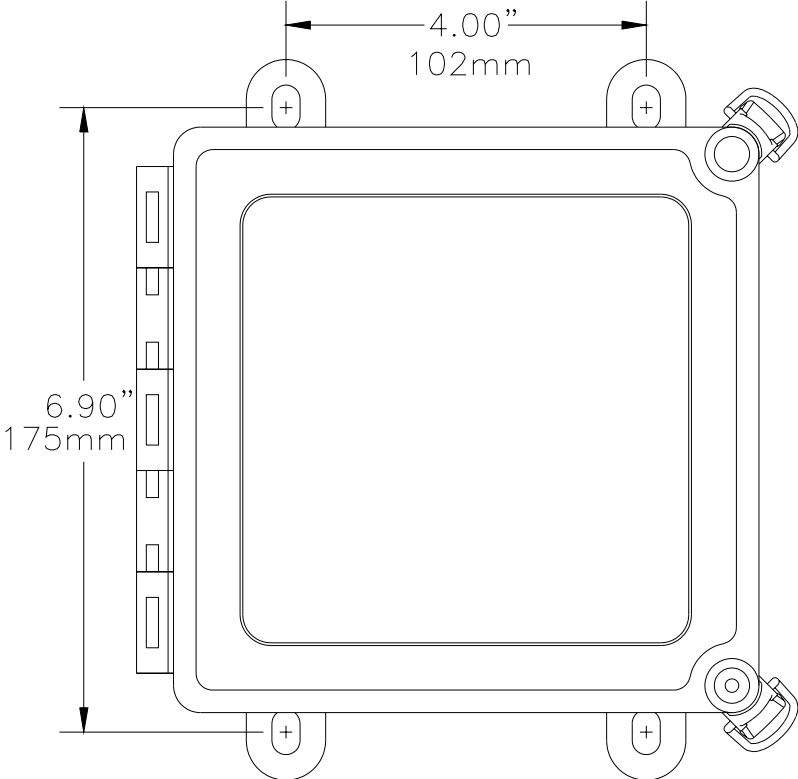

Figure 3-1. IMU-II/S Mounting Dimensions

INSTALL CABLES

The cables needed are:

- Pulse Data and Alarm cables
- Grounding cable
- Serial interface cable(s)

1. Loosen the end cap on the left and right bushings.

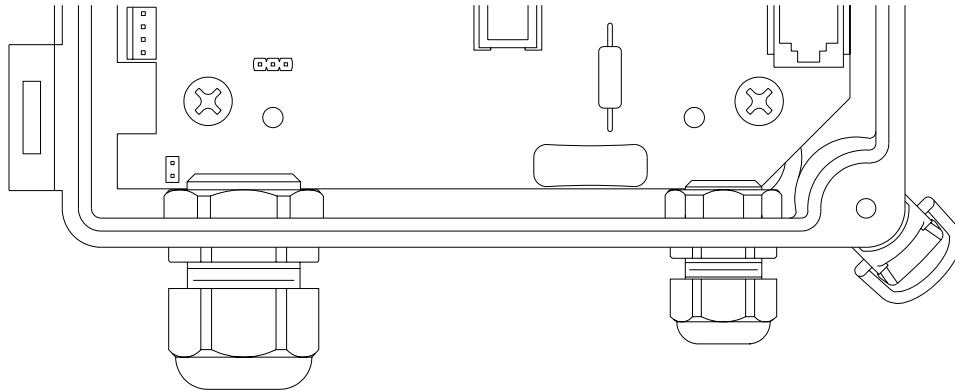

Figure 3-2. Enlarged view of bushings.

2. Feed the input cables and the alarm cables through the left bushing on the bottom of the IMU-II/S.
3. Feed the telephone cable through the right bushing of the IMU-II/S. Install a RJ-11 plug onto the telephone cable. Verify that the red and green wires are connected to the two inside pins of the RJ-11 plug. These two wires are the Tip and Ring wires and are used by the IMU-II/S to connect to the telephone network.

Telephone Line Station Protector Installation

Before installing the IMU-II/S, you should verify that the telephone line is functional by following the steps listed below:

1. Install the telephone receptacle (telephone network interface) if it has not been previously installed.
2. Mount the TII Telephone Station Protector in a suitable location. Wiring of the station protector is shown below:

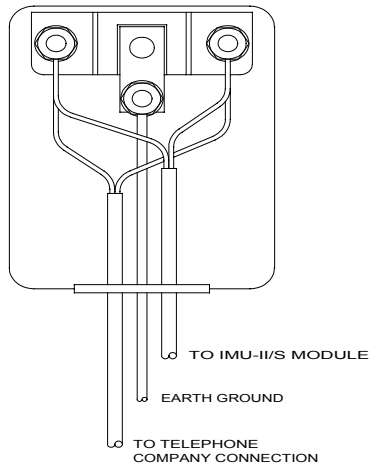

Figure 3-3. Wiring of surge protector.

3. Connect one end of the 12 AWG earth ground wire to the center terminal on the TII protector. Appendix B provides a data sheet detailing the TII Telephone Station Protector.
4. Connect the other end of the earth ground wire to a solid earth ground in conformance with national and local electrical code regulations.
5. Route the telephone cables from the telephone company connector and the IMU-II/S through the bottom of the TII station protector.
6. Connect the red wires from both of the telephone cables to the left screw inside the TII station protector.
7. Connect the green wires from both of the telephone cables to the right screw inside the TII station protector.
8. Connect the telephone test set to the telephone line plug going to the IMU-II/S board.
9. Check for a dial tone. (This procedure will test the telephone cable and the telephone line.)

NOTE

If no dial tone is detected, a problem exists with the telephone line which must be repaired before continuing the IMU-II/S installation process.

10. If the IMU-II/S is to be enabled to auto-dial, dial the telephone number assigned to the central modem.
11. Listen to the telephone receiver to verify that the central modem answers the call and responds with an answer tone.
12. Disconnect the telephone test set.

Attach Input Cables

Connection of the three data and alarm cables to the terminal strip are described below. You may unplug the terminal strip from the unit for easier access when making these connections. Figure 3-2 shows the standard IMU-II/S terminal strip. Figure 3-3 shows the IMU-II/S (optional Serial Port Multiplexer) terminal Strip. Figure 3-4 illustrates how the data, alarm, and telephone cables should be routed and attached to the IMU-II/S. Please refer to Chapter Four for more information on the IMU-II/S alarms.

- **Input 1**

Input 1, (TB1-3, TB1-5), can be configured by the Metretek Programmer as either a Form A pulse counting data input or a Form A alarm input. The input transducer must provide an input closure of greater than 40 msec.

- **Input 2**

Input 2, (TB1-4, TB1-5), can be configured by the Metretek Programmer as either a Form A pulse counting data input or a Form A alarm input. The input transducer must provide an input closure of greater than 40 msec.

- **Alarm**

The Alarm input, (TB1-1, TB1-2), is a normally open alarm input and can be wired as a customer specified alarm. The alarm transducer must provide an input closure of greater than 40 msec.

- **Tamper**

Tamp+ is a normally closed alarm input and is usually prewired from the factory as a tamper alarm and is connected to the magnetic switch found on the IMU-II/S enclosure side wall.

NOTE

If the transducer outputs are polarity sensitive, connect the negative side of the output to the common or negative input connection.

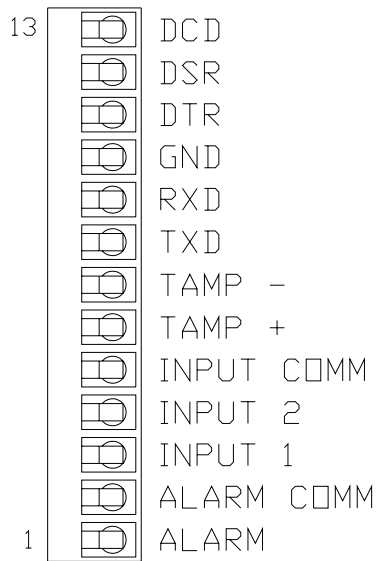

Figure 3-4. IMU-II/S Terminal Strip.

SERIAL PORT MULTIPLEXER – TB1														
15	14	13	12	11	10	9	8	7	6	5	4	3	2	1
TXD 1	RXD 1	DSR 1	DTR 1	GND 1	TXD 2	RXD 2	DSR 2	DTR 2	GND 2	TAMP -	TAMP +	INP COMM	INP 2	INP 1

Figure 3-5. IMU-II/S Serial Port Multiplexer Terminal Strip.

NOTE

When using the Serial Port Multiplexer, the board should be plugged into terminal block positions 3 through 13 on the IMU-II/S board.

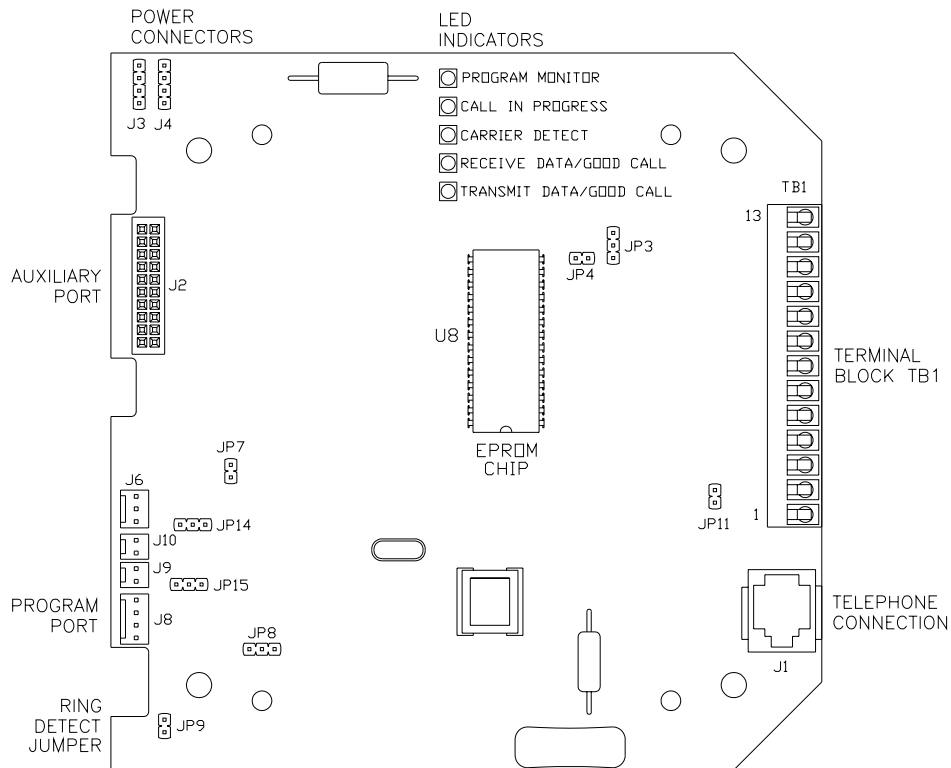

Figure 3-7. IMU-II/S Board.

Serial Data Connection

The connection of the DTE's serial port to the IMU-II/S is made through the IMU-II/S's terminal strip. You may unplug the terminal strip from the unit for easier access while making these connections.

The following RS-232 signals are present on the Standard IMU-II/S:

1. TXD Output Transmit Data from IMU-II/S.
2. RXD Input Receive Data to IMU-II/S.
3. DSR Output Data Set Ready - Set high by IMU-II/S when ready to communicate.
4. DTR Input Data Terminal Ready - Set high by DTE when the DTE wishes to communicate. Wakes IMU-II/S from idle.
5. DCD Output Carrier Detect - Set high by IMU-II/S when carrier is detected.

The following RS-232 signals are present on the IMU-II/S with the Serial Port Multiplexer (The Serial Port Multiplexer board should be plugged into terminal positions 3 through 13 on the IMU-II/S board.) installed:

1. TXD1 Output Port 1 Transmit Data from IMU-II/S.
2. RXD1 Input Port 1 Receive Data to IMU-II/S.
3. DSR1 Output Port 1 Data Set Ready - Set high by IMU-II/S when ready to communicate.
4. DTR1 Input Port 1 Data Terminal Ready - Set high by DTE when the DTE wishes to communicate. This signal wakes the IMU-II/S from idle mode.
5. TXD2 Output Port 2 Transmit Data from IMU-II/S.
6. RXD2 Input Port 2 Receive Data to IMU-II/S.
7. DSR2 Output Port 2 Data Set Ready - Set high by IMU-II/S when ready to communicate.
8. DTR2 Input Port 2 Data Terminal Ready - Set high by DTE when the DTE wishes to communicate. This signal wakes the IMU-II/S from idle mode.

To connect a DTE serial port to the IMU-II/S, perform the following steps:

1. Feed the serial cable from the DTE through the left bushing on the IMU-II/S.
2. Connect the DTE's transmit data wire to the IMU-II/S's RXD terminal.
3. Connect the DTE's receive data wire to the IMU-II/S's TXD terminal.
4. Connect the DTE's signal ground wire to the IMU-II/S's GND terminal.
5. If necessary, connect the DTE's data terminal ready wire to the IMU-II/S's DSR terminal.
6. If necessary, connect the DTE's data set ready wire to the IMU-II/S's DTR terminal.
7. If necessary, connect the DTE's carrier detect input wire to the IMU-II/S's DCD terminal. This connection is not available if a Serial Port Multiplexer is installed.

If you are unsure about which signals should be connected, refer to Chapter 4, which explains the operation of the IMU-II/S.

VERIFY RING DETECT JUMPER

Ring Detect allows the IMU-II/S to answer incoming calls from the central computer system. If you requested ring detect capabilities on your IMU-II/S, a jumper should have been installed when it was shipped. Verify that the jumper JP9 on the IMU-II/S board is present. To determine the exact location of JP9, refer to Figure 3-5.

- To enable ring detect, install JP9 on the IMU-II/S board.
- To disable ring detect, remove the jumper JP9 from the IMU-II/S board.

INSTALL POWER SOURCE

Lithium Batteries

1. Install the lithium battery pack on the door of the IMU-II/S enclosure as shown in figure 3-6. Secure the battery with the tie-wraps supplied.
2. Connect the plug from the lithium battery pack to either battery connector, J3 or J4, on the IMU-II/S board. Figure 3-6 shows the exact location of the battery connectors.

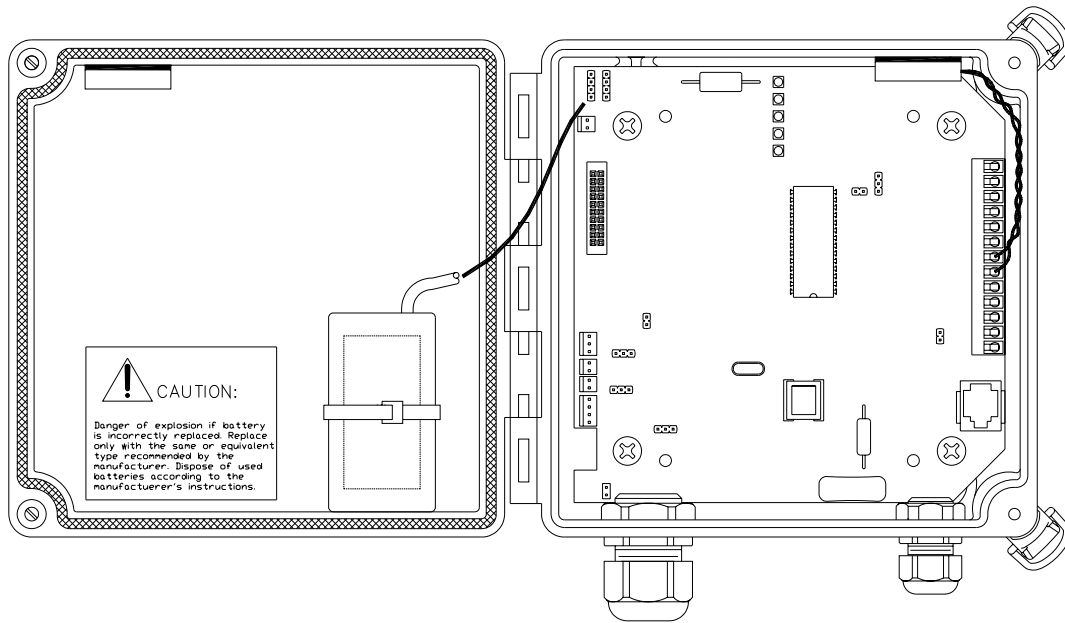

Figure 3-8. Lithium Battery Powered IMU-II/S.

VERIFY POWER-UP

Immediately after the IMU-II/S is powered up, the FIRMWARE MONITOR LED will turn on solid green while it runs its RAM test. If the RAM test fails the FIRMWARE MONITOR and OFFHOOK LEDs will be turned off and all other LEDs will be turned on. If the test is successful the IMU-II/S will momentarily light the RD LED. The FIRMWARE MONITOR LED will then begin to blink. If the IMU-II/S is enabled to auto-dial, it will immediately go off-hook and attempt to call-in to the central computer modem to report a Unit Reset Alarm.

NOTE

Whenever the IMU-II/S detects a TAMPER alarm (enclosure door open), the LEDs will be activated for 4-1/4 minutes. To re-enable the LEDs after the 4-1/4 minute period has expired, close and reopen the IMU-II/S enclosure.

PROGRAM IMU-II/S

Programming and configuration of the IMU-II/S is accomplished using the Metretek Programmer Software. This software operates on a portable computer and programs the IMU-II/S through the Serial Interface Cable. This cable connects to the IMU-II/S's serial port through which the units phone number, type of dialing, unit identification number, and other parameters are programmed.

1. Connect the Serial Interface Cable to the IMU-II/S board at J8. Refer to Figure 3-5 for the exact location of the connector.
2. Refer to Manual No. 900203, Metretek Programmer Hardware and Software Users Manual for complete directions on how to program your IMU-II/S.

VERIFY OPERATION OF IMU-II/S

CAUTION

The IMU-II/S cannot communicate with the Metretek Programmer and the central computer modem simultaneously. When the IMU-II/S is being programmed/configured, the unit must not be communicating with the central modem. Likewise when the IMU-II/S is communicating with the central modem, the Serial Interface Cable should not be connected to the IMU-II/S.

Verifying Auto-Answer

If the IMU-II/S is enabled for auto-answer, follow the steps below to verify correct IMU-II/S operation.

1. Connect the IMU-II/S telephone jack J1 and the telephone test set in parallel and then connect them to the telephone company line.
2. Place the telephone test set in the monitor mode.
3. Have the central computer operator call the IMU-II/S using the central modem. This can be accomplished using the DTE manufacturers software, a software communications package such as PROCOMM or the Metretek Data Collection Software.
4. Listen to the call using the telephone test set.

5. After the ring is detected, verify that the OFFHOOK (OH) Light Emitting Diode (LED) located on the IMU-II/S has answered the call. Table 3-1 describes the functions of all the LEDs on the IMU-II/S board.

NOTE

Whenever the IMU-II/S detects a TAMPER alarm (enclosure door open), the LEDs will be activated for 4 ¼ minutes. To re-enable the LEDs after the 4 ¼ minute period has expired, close and reopen the IMU-II/S enclosure.

6. After approximately 5-6 seconds, verify that the CARRIER DETECT (CD) LED lights to signify a good connection with the central computer.

If the OFFHOOK LED or the CARRIER DETECT LED does not light, refer to Chapter Five, On-site Troubleshooting.

LED NAME	DEFINITION
1 (FIRMWARE MONITOR)	Blinks at 1Hz to show that the system is operating properly in Metretek Mode.
2 (CALL IN PROGRESS)	Off-Hook - Lights to indicate the IMU-II/S is off-hook.
3 (CD)	Carrier Detect - Lights to indicate that the IMU-II/S detects a carrier signal from a remote modem.
4 (RECEIVE DATA / GOOD CALL)	Receive Data / Good Call - When the IMU-II/S is off-hook, this LED will light to indicate that the IMU-II/S is receiving data from the central computer. When the IMU-II/S is on-hook, this LED will be lit if communications with the central computer was successful. This LED will be turned off if communications were unsuccessful.
5 (TRANSMIT DATA / GOOD CALL)	Transmit Data / Good Call - When the IMU-II/S is off-hook, this LED will light to indicate that the IMU-II/S is transmitting data to the central computer. When the IMU-II/S is on-hook, this LED will be lit if the communications with the Central Computer was successful. This LED will be turned off if communications were unsuccessful.

Table 3-1. LED Functions.

Verify Auto-Dial Operation

If the IMU-II/S is enabled to auto-dial when an alarm occurs, follow the steps below to verify correct IMU-II/S operation. Two calls may be required to test the IMU-II/S since it may be programmed to auto-dial two different phone numbers.

1. Connect the IMU-II/S telephone jack J1 and the telephone test set in parallel and then connect them to the telephone company line.
2. Place the telephone test set in the monitor mode.
3. To force a test call to phone number 1 (standard IMU-II/S and IMU-II/S with SPM installed), momentarily short the alarm input (TB1-1 to TB1-2). If the IMU-II/S is configured for dual serial ports and Input 2 is configured as an alarm input you can trigger a call to phone number 2 by momentarily shorting the Input 2 terminal to the Input common terminal (TB1-4 to TB1-5).
4. Listen to the call with the telephone test set.
5. Verify that the OFFHOOK (OH) Light Emitting Diode (LED) located on the IMU-II/S board illuminates signifying that the IMU-II/S has gone OFFHOOK to dial the central computer's telephone number. Table 3-1 describes the function of the LED's on the IMU-II/S board.

NOTE

Whenever the IMU-II/S detects a TAMPER alarm (enclosure door open), the LEDs will be activated for 4 ¼ minutes. To re-enable the LEDs after the 4 ¼ minute period has expired, close and reopen the IMU-II/S enclosure.

6. After dialing the central computer's phone number and connecting with the central modem, the IMU-II/S's CARRIER DETECT (CD) LED should illuminate signifying a good connection with the central computer.

If the OFFHOOK or the CARRIER DETECT indicator do not light, refer to Chapter Five, On-site Troubleshooting.

CLOSE THE IMU-II/S

To close the IMU-II/S, perform the following steps:

1. Disconnect the telephone test from the telephone jack.
2. Plug the telephone cable for the IMU-II/S into J1 on the IMU-II/S board.
3. Tighten the bushings on the bottom of the IMU-II/S.
4. Close and latch the door of the IMU-II/S enclosure.
5. Padlock the IMU-II/S enclosure and attach a security seal (optional).

NOTES

CHAPTER FOUR: IMU-II/S OPERATIONS

INTRODUCTION

This Chapter explains the operation of the Standard IMU-II/S and the Dual Port IMU-II/S (IMU-II/S with Serial Port Multiplexer option installed). It will instruct the user how the IMU-II/S can be used to communicate with the central computer and the DTE device.

IMU-II/S COMMUNICATIONS

In addition to its pulse collection capabilities, the IMU-II/S can also be used as a communications link between the central computer modem and the DTE device. There are several different ways that this link can be established and maintained. The following sections explain how the link is established using the standard IMU-II/S and the Dual Port IMU-II/S. After the initial connection with the central modem the IMU-II/S will attempt to communicate using Metretek protocol. If the IMU-II/S is unable to establish a Metretek connection within 3 seconds, it will default to a transparent link, simply connecting the central computer to the DTE. In this mode the central computer will have direct control over the DTE via the IMU-II/S.

Communications Parameters

The serial channel communications parameters are programmable by the use of the Metretek Programmer. A byte within the configuration EEPROM is used to hold this information. However, the bit rate of the serial interface will be determined by the bit rate that is being used on telephone line. These parameters must be programmed to match the communications parameters of the DTE device.

The programmable serial channel parameters are the following:

- Number of data bits - 7 or 8 bits
- Number of stop bits - 1, 1.5, or 2 bit(s)
- Parity - odd, even or none

The standard configuration will be 8 data bits, 1 stop bit and no parity.

The maximum modem connect bit rate can also be programmed. This parameter is utilized to limit the bit rate that will be used when connecting with the host modem. For example, if the DTE device is set to communicate at 1200 bits/sec, this parameter should be set to 1200 bits/sec to prevent the IMU-II/S from connecting with the host modem at the default rate of 2400 bits/sec.

When using a Dual Port IMU-II/S these communications parameters must be set for each DTE port.

Standard IMU-II/S Communications

IMU-II/S Call Origination

The IMU-II/S can be triggered to originate a call by two different methods.

1. Auto-dial when a hardware alarm or call-back time occurs.
This method of auto-dial can be used by a DTE device that does not have AT command capability but has a contact closure output. This contact closure output is connected to a IMU-II/S customer alarm input. If the IMU-II/S auto-dials but the alarms are not cleared the IMU-II/S will enter its call retry mode and continue to auto-dial the host until the alarms are cleared. Refer to the section entitled IMU-II/S Alarms - Status Flags for details on the clearing and viewing of alarms.
2. Call origination under AT command control.
The IMU-II/S can be forced by the DTE to originate a call by the use of AT commands. The steps required to originate a call using AT commands is shown in Figure 4-1.
After the IMU-II/S detects that its DTR input has been activated it will wake-up and activate the DSR output. If an AT command string is not received within 20 seconds the IMU-II/S will clear the DSR output and go back to the idle state.

IMU-II/S Answering

The IMU-II/S can be programmed to auto-answer by the Metretek Programmer. The number of rings on which to answer is also programmable. After detecting the appropriate number of ring signals the IMU-II/S will go off-hook and attempt to connect with the originating modem. After the connection, if ASCII alarm download is enabled, the IMU-II/S will transmit its unit ID and any current alarm data to the originating modem. After this information is sent, a transparent link will be made between the IMU-II/S's modem port and the DTE port.

Dual Port IMU-II/S Communications

The Dual Port IMU-II/S consists of the standard IMU-II/S with the optional Serial Port Multiplexer (SPM) installed. The SPM plugs into the IMU-II/S's input terminal block and allows a single IMU-II/S to communicate with two DTE devices via their RS-232 ports. Both DTE serial ports can be individually addressed from the host modem by sending a port select command to the IMU-II/S. The port select command consists of the string "+-+PAXXXXXX" or "+-+paXXXXXX", where the XXXXXX is the Unit ID of the specific port with which the host computer wishes to connect. After receiving this message the IMU-II/S will respond with the message string "CONNECTION WITH PORT XXXXXX NOW TRANSPARENT", where XXXXXX is the Unit ID of port. The port select command may be sent by the central computer to the IMU-II/S at any time after the initial connection is made.

The dual port capability must be enabled via the Metretek Programmer.

Dual Port IMU-II/S Call Origination

The IMU-II/S can be triggered to originate a call by two different methods.

1. Auto-dial when a hardware alarm occurs.

This method of auto-dial can be used by a DTE device that does not have AT command capability but has a contact closure output. This contact closure output is connected to an IMU-II/S customer alarm input.

The Dual Port IMU-II/S has the ability to auto-dial two different phone numbers. The IMU-II/S will auto-dial phone number 1 when any alarm excluding the Input 2 alarm 1 occurs. The IMU-II/S will auto-dial phone number 2 only when a Input 2 alarm is detected. If the IMU-II/S auto-dials but the alarms are not cleared the IMU-II/S will enter its call retry mode and continue to auto-dial the host until the alarms are cleared. Refer to the Alarm Maintenance section of this chapter for details on the clearing and viewing of alarms.

2. Call origination under AT command control.

The IMU-II/S can be forced to originate a call by using AT commands. The steps shown in Figure 4-1 must be performed to originate a call.

After the IMU-II/S detects that its DTR input has been activated it will wake-up and activate the DSR output on port 1. If an AT command string is not received from port 1 within 2 seconds the IMU-II/S will clear the port 1 DSR and activate the port 2 DSR. The IMU-II/S will then look for an AT command string from port 2. If the command is not received within 2 seconds the IMU-II/S will switch back to port 1 and repeat the process. The IMU-II/S will repeat the initial sequence 5 times in an effort to establish a connection.

Dual Port IMU-II/S Answering

The Dual Port IMU-II/S can be programmed to auto-answer by the Metrotek Programmer or via the ATSO command. After answering and connecting with the originating modem the IMU-II/S will wait a programmable timeout period (0 to 30 seconds) for a port select command. If the port select command is not received from the host computer the IMU-II/S will operate according to the programmable port default mode. The port default mode can be programmed to be one of the following:

Port 1 - The IMU-II/S will default to a connection to DTE port 1 after the timeout period expires.

Port 2 - The IMU-II/S will default to a connection to DTE port 2 after the timeout.

Alternate - The default port will alternate between port 1 and port 2 after the timeout.

For Example: 1st Call - IMU-II/S defaults to port 1.

2nd Call - IMU-II/S defaults to port 2.

3rd Call - IMU-II/S defaults to port 1. etc...

None - The IMU-II/S will abort the phone connection if a port is not selected within the timeout period.

The steps that are followed by the Dual Port IMU-II/S when answering are shown in Figure 4-2.

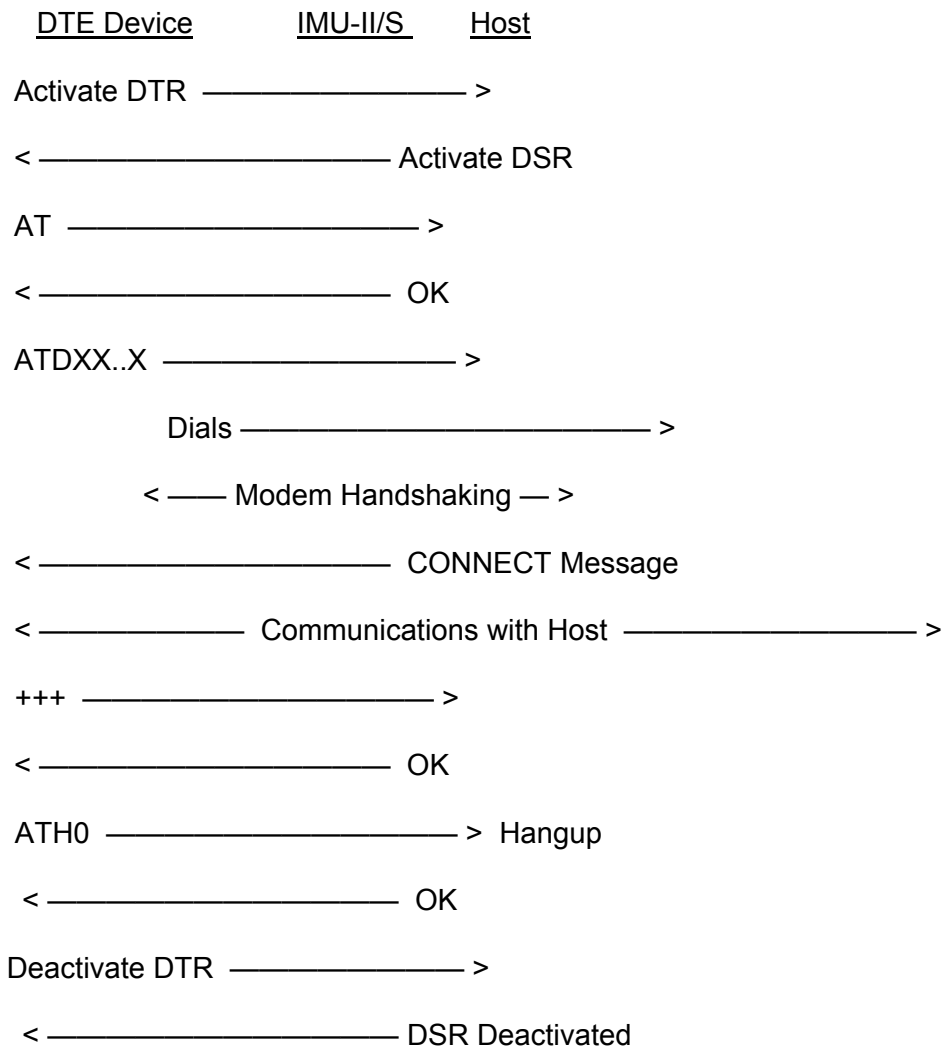

Figure 4-1. AT Command Call Origination.

NOTES

1. After the Dual Port IMU-II/S detects that its DTR input has been activated it will wake-up and activate the DSR output on port 1. If an AT command string is not received from port 1 within 2 seconds the IMU-II/S will clear the port 1 DSR and activate the port 2 DSR. The IMU-II/S will then look for an AT command string from port 2. If the command is not received within 2 seconds the IMU-II/S will switch back to port 1 and repeat the process. The IMU-II/S will repeat the initial sequence 5 times in an effort to establish a connection.
2. After DSR is deactivated the Dual Port IMU-II/S will return to a low power idle state.
3. During the AT Command Call Origination, the IMU-II/S does not attempt to connect using Metrotek protocol but goes immediately to transparent mode.

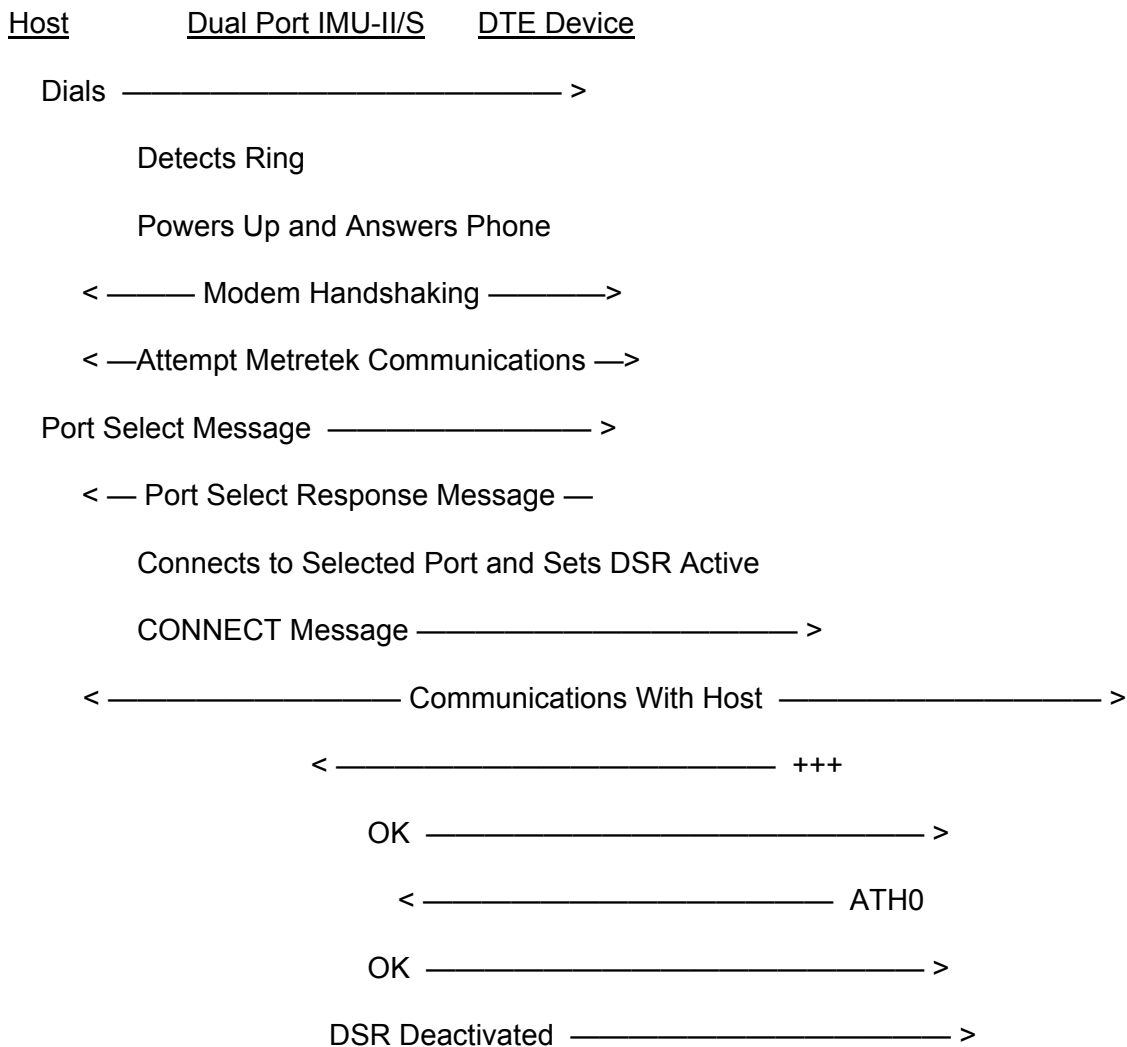

Figure 4-2. Dual Port IMU-II/S Answering.

NOTES

1. Port select command message: ++PAXXXXXX (X = ASCII hex number, 0-F)
2. Port select response message: CONNECTION WITH PORT XXXXXX NOW TRANSPARENT
3. If a port select command message is not received within the programmable timeout period the IMU-II/S will default to a port connection depending on the preprogrammed port default mode.
4. The IMU-II/S will delay 1 second after setting DSR active before sending the CONNECT message.
5. If the Host ends the communications session by disconnecting, the IMU-II/S will send a "NO CARRIER" message to the DTE.

AT COMMAND SET COMPATIBILITY

An IMU-II/S can be controlled by the DTE by the use of the AT commands shown in Table 4-1. The IMU-II/S will respond to the AT commands with the result codes that are shown in Table 4-2.

<u>Command</u>	<u>Function</u>
AT	Test for OK result code
ATH0	Go on-hook
ATH1	Go off-hook
ATE0	Character echo off
ATE1	Character echo on
ATDTXXX...X	Go off-hook, tone dial and connect
ATDPXXX...X	Go off-hook, pulse dial and connect
	Additional ATD dialing characters
	W - Wait for dial tone
	, - dialing delay
ATV0	Set result code format to numeric codes
ATV1	Set result code format to verbal codes
ATS0=XX	Set number of rings on which to answer (0 - 15), If set to 0 then auto answer is disabled
ATS8=XX	Set the delay value of the ATD delay character (,)
+++	Escape to command mode
ATO0	Return to online state
AT\$	Display AT command set

Table 4-1. IMU-II/S AT Commands.

	<u>Numeric</u>	<u>Verbal</u>
0	OK	
1	CONNECT	
2	RING	
3	NO CARRIER	
4	ERROR	
5	CONNECT 1200	
6	NO DIAL TONE	
7	BUSY	
8	NO ANSWER	
10	CONNECT 2400	

Table 4-2. IMU-II/S result codes.

IMU-II/S ALARMS - STATUS FLAGS

The IMU-II/S has various alarms and status flags. If the IMU-II/S is enabled to auto-dial, the alarm condition will cause the IMU-II/S to immediately place a call to the central computer. Status flags will not trigger a call to the central computer, but they will be reported on the next communications with the central computer. These alarms and status flags are designed to inform the computer that an exception condition exists at the IMU-II/S. If a Metretek protocol connection is established these alarm/status flags will be sent to the host computer using Metretek protocol. If the IMU-II/S fails to connect using Metretek protocol, the IMU-II/S will default to the transparent mode and the alarms and status flags will be sent to the central modem as an ASCII string at the beginning of communications. Preceding these alarm strings the IMU-II/S will transmit its unit identification number using the format listed below.

UID# NNNNNN

This unit ID number is read from the IMU-II/S's configuration memory and is programmed by the Metretek Programmer.

If the IMU-II/S is enabled for dual port operation it will call phone number 1 when all alarms except customer alarm 2 occurs. A customer alarm 2 occurrence will cause the IMU-II/S to call phone number 2. If the IMU-II/S is calling phone number 1 it will report Port 1 Unit ID. If the IMU-II/S is calling phone number 2 it will report Port 2 Unit ID.

If the IMU-II/S is not enabled to auto-dial, the active alarms will be reported at the next scheduled communication with the central computer.

Table 4-3 shows the ASCII string that is transmitted for each specific IMU-II/S status/alarm flag when in transparent mode. The alarm strings that are transmitted when a customer alarm 1 or customer alarm 2 occurs are programmable via the programming port by using a laptop PC and the Metretek Programmer software. These programmable alarm strings can be up to 20 characters in length.

TRANSPARENT MODE ALARM MAINTENANCE COMMANDS

The alarms reported in transparent mode must be cleared by the central computer by transmitting the ASCII string "+-+clarms" to the IMU-II/S. The alarms can also be cleared by sending the IMU-II/S the string "+-+ca" or "+-+CA". The IMU-II/S will respond with an "OK" message after the flags have been cleared. If the IMU-II/S is enabled for auto-dial and an alarm occurs the clear alarm string must be sent to the IMU-II/S to acknowledge the receipt of the alarm. If the call is aborted and the alarm has not been cleared the unit will enter the call retry mode and call back at the programmed call retry interval. The IMU-II/S will remain in the call retry mode until it receives the clear alarm string from the central computer.

AFTER CONNECTION WITH THE IMU-II/S AND THE INITIAL TRANSMISSION OF THE ALARMS, THE CENTRAL COMPUTER MAY REQUEST THAT THE ALARMS BE RETRANSMITTED BY SENDING THE SCAN ALARMS COMMAND ("+-+SA" OR "+-+ SA") TO THE IMU-II/S. THE IMU-II/S WILL RESPOND BY RETRANSMITTING THE UNIT ID AND ALARM MESSAGES.

ALARM	ASCII STRING	DESCRIPTION
LOW BATTERY	*LOW BATTERY ALARM* (*see note 2)	The IMU-II/S's battery is nearing a discharged condition and the battery needs replacement. The IMU-II/S checks its battery voltage level at the beginning and end of each call.
CALL RETRY	*CALL RETRY ALARM*	The IMU-II/S's previous call was unsuccessful. (A call is attempted again at the primary retry rate for the number of times specified for a primary retry in the IMU-II/S's configuration EEPROM. Then, calls are placed at the secondary retry rate specified in the IMU-II/S's configuration EEPROM until the call is successful.)
UNIT RESET	*UNIT RESET ALARM*	The IMU-II/S module is forced to restart because it's being installed or a program interruption has been detected.
INPUT 1 ALARM (see Note 1)	*CUSTOMER ALARM 1*	Normally open Customer-specified alarm, activated by closing the circuit. (TB1-3 to TB1-5)
INPUT 2 ALARM (see Note 1)	*CUSTOMER ALARM 2*	Normally open Customer-specified alarm, activated by closing the circuit. (TB1-4 to TB1-5)
TAMPER ALARM	*TAMPER ALARM*	The normally closed tamper alarm indicates that the tamper circuit has been activated. (A door switch that is normally closed has opened.)
CUSTOMER ALARM	*CUSTOMER ALARM*	Normally open alarm input. Activated by closing the circuit. (TB1-1 to TB1-2)
AC OFF	*AC OFF ALARM*	AC power to the IMU-II/S has been off for 5 minutes.
AC ON	*AC ON ALARM*	AC power to the IMU-II/S has returned and has been on for 5 minutes.

Table 4-3. IMU-II/S Status Flags.

Note 1: The ASCII alarm strings that are reported for Input 1 Alarm and Input 2 Alarm are programmable using the Metretek Programmer.

Note 2: Due to battery voltage fluctuations over temperature and load, we recommend that the IMU-II/S's battery not be changed until the IMU-II/S has reported a low battery alarm for 7 consecutive days.

CHAPTER FIVE: ON-SITE TROUBLESHOOTING

INTRODUCTION

This chapter explains the troubleshooting steps you should try before contacting Metretek's Customer Service Department.

GENERAL TROUBLESHOOTING

If the IMU-II/S does not call, does not answer or does not connect with the central modem, perform the following procedures:

Check for the Telephone Line Dial Tone

1. Unplug the telephone cable from J1 on the IMU-II/S board. For the exact location of J1, refer to Figure 5-1.
2. Connect the telephone test set to the telephone company line.
3. Go off-hook and listen for a dial tone.

If a dial tone is not heard, a problem exists with the telephone line. Contact your local telephone company in order to have the phone line repaired.

If a dial tone is heard, a problem exists elsewhere in the system.

4. Plug the telephone cable back into the IMU-II/S.

Check Battery Voltage

1. Close and open the IMU-II/S enclosure. The IMU-II/S enclosure must be closed for a minimum of 2 seconds. This will cause the IMU-II/S to detect a tamper alarm and switch to the high power mode.
2. Connect a digital voltmeter to the available battery connector, J3 or J4.
3. Verify that the battery voltage is as follows:

Lithium Battery Pack - greater than 3.1 Vdc

If the battery is lower than the required voltage, follow the direction in Chapter Six to replace the battery.

If the battery level is acceptable, reset the IMU-II/S by following the directions below.

Reset the IMU-II/S

Reset the IMU-II/S by momentarily shorting the RESET jumper JP4. If the unit is enabled for auto-dial and a phone number has been programmed into the IMU-II/S, the unit should go off-hook and attempt to call the central computer in approximately 10 to 15 seconds. If the unit still will not function properly, refer to Chapter 7, Return Equipment Procedure, for instructions to return your equipment.

Immediately after the reset, the IMU-II/S will turn the green FIRMWARE MONITOR LED on solid while it runs its RAM test. If the RAM test fails, the FIRMWARE MONITOR and OFFHOOK LEDs will be turned off and all other LEDs will be turned on. If the test is successful, the IMU-II/S will momentarily light the RD LED. The FIRMWARE MONITOR LED will then begin to blink.

NOTE

Whenever the IMU-II/S detects a TAMPER alarm (enclosure door open), the LEDs will be activated for 4-1/4 minutes. To re-enable the LEDs after the 4-1/4 minute period has expired, close and reopen the IMU-II/S enclosure.

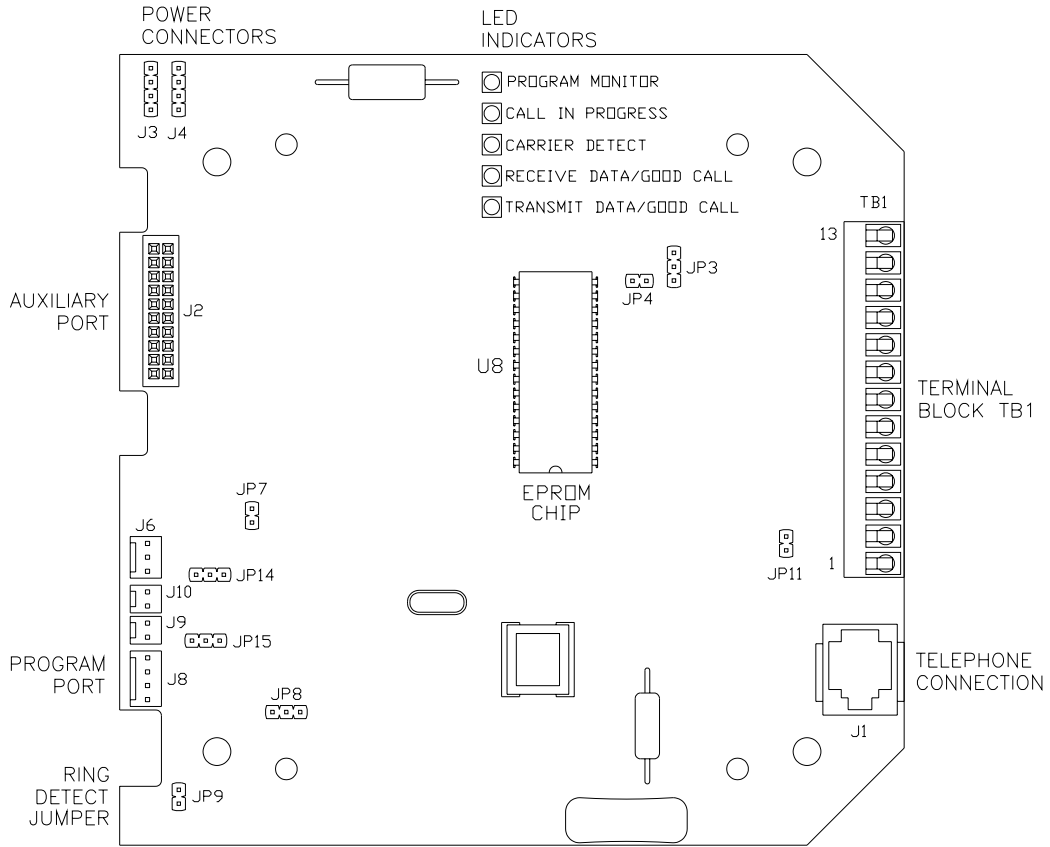

Figure 5-1. IMU-II/S Board.

ADDITIONAL AUTO-ANSWER TROUBLESHOOTING

If the unit will not properly auto-answer, perform the following steps:

1. Verify that the ring detect jumper, JP9, is in place.
2. Verify that the IMU-II/S has been programmed to answer on the correct number of rings with the Metretek Programmer software, the serial programming cable and a PC. See the list of materials for part numbers if this equipment needs to be obtained.

ADDITIONAL AUTO-DIALING TROUBLESHOOTING

If the unit goes off-hook but does not connect with the central modem perform the following steps:

1. Verify that the correct phone numbers have programmed into the IMU-II/S with the Metretek Programmer.
2. Verify that the IMU-II/S has been configured for auto-dialing with the Metretek Programmer software.
3. Call the central computer operator and verify that the central modem is on-line and ready to receive calls.

NO COMMUNICATION WITH DTE

If the Central Computer is not able to communicate with the Electronic corrector, perform the following steps:

1. Verify that the IMU-II/S serial port is correctly connected to the DTE as outlined in Chapter 3.
2. Verify that the communications parameters (parity, number of data bits, number of stop bits) are correctly programmed for the serial interface with the Metretek Programmer software, the serial programming cable, and a PC. The communications parameters of the IMU-II/S must match the communication parameters of the DTE device.
3. Verify that the DTE serial port has been configured for the correct number of data bits, number of stop bits, and parity. The bit rate of the DTE serial port must match the bit rate of the central computer; either 300, 1200, or 2400.

NOTE

When the IMU-II/S is operating in the transparent mode, the bit rate of the IMU-II/S will be determined by the bit rate of the modem to which it makes a connection. For example, if the IMU-II/S is called by a V.22 bis 2400 bits/sec modem, the IMU-II/S will switch its data rate to 2400 bits/sec on its serial interface and on its modem interface.

NO COMMUNICATION WITH MERCURY INSTRUMENTS ECAT

If the central computer is not able to communicate with the electronic corrector, perform the following steps:

1. Verify that the IMU-II/S is correctly connected to the Mercury Instruments ECAT as shown below:

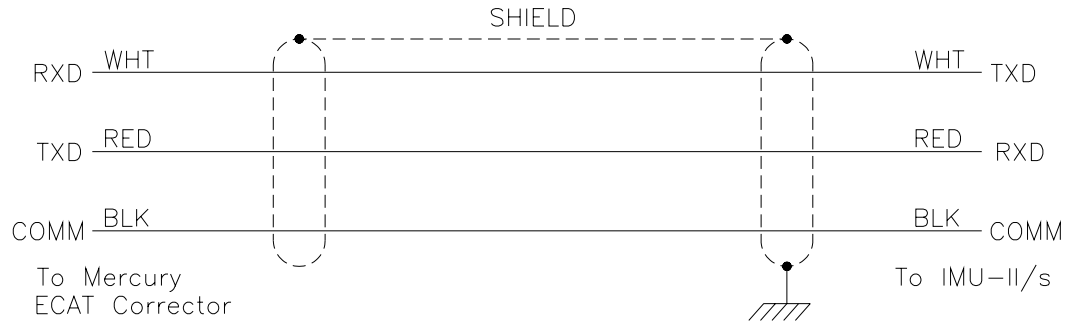

2. Verify that the communications parameters (parity, number of data bits, number of stop bits) are correctly configured using the Metretek programmer cable and software. The communications parameters for the Mercury ECAT should be 8 data bits, 1 stop bit, and no parity.
3. Verify that the Mercury ECAT serial port has been configured for the correct bit rate (Item 126). The bit rate of the ECAT serial port must match the bit rate of the IMU-II/S, either 1200 or 2400 bps.

NO COMMUNICATION WITH THE INLINE CORRECTOR

If the central computer is not able to communicate with the electronic corrector, perform the following steps:

1. Verify that the IMU-II/S is correctly connected to the Inline corrector as shown below:

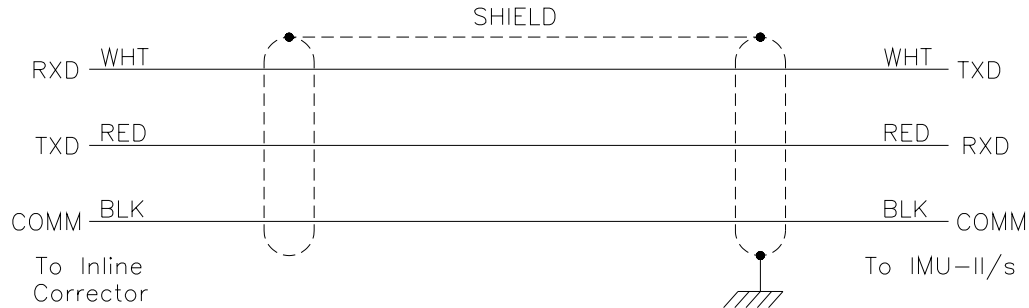

2. Verify that the communications parameters (parity, number of data bits, number of stop bits) are correctly configured using the Metretek programmer cable and software. The communications parameters for the Inline corrector should be 8 data bits, 1 stop bit, and no parity.
3. No additional serial port configuration of the Inline corrector is required due to the auto-baud rate detect function that is provided.
4. Make certain that the write protect switch is not activated. Calls with the central computer will not be successful if this switch is in the 'protect' position.
5. Check that the password function has not been enabled. If passwords are enabled, the IMU-II/S will not be able to establish communications with the Inline corrector.
6. Check the RS-232 communication speed that has been programmed into the IMU-II/S. A good starting point is to try the settings listed below, as these typically work well with most Inline correctors. A slower bit rate may be necessary if the serial cable has a long length.

BIT RATE = 2400
DATA BITS= 8
STOP BITS= 1
PARITY = NONE

NOTE

When the IMU-II/S is operating in the transparent mode, the bit rate of the IMU-II/S will be determined by the bit rate of the modem to which it makes a connection. For example, if the IMU-II/S is called by a V.22bis 2400 bps modem, the IMU-II/S will switch its data rate to 2400 bps on its serial interface and on its modem interface.

CHAPTER SIX: MAINTENANCE

INTRODUCTION

Your Metretek IMU-II/S will operate with very little maintenance. This chapter is to inform you of the parts of your Metretek equipment which should be maintained.

BATTERY

The IMU-II/S operates on a single lithium battery pack. Replace the battery when a low battery alarm occurs. The IMU-II/S's battery life is dependent on the frequency of the calls, the length of each call and the operating temperature. For an IMU-II/S with a lithium 'D' size battery, typical life will be approximately 2.5 to 3 years.

NOTE

Due to battery voltage fluctuations over temperature and loads, we recommend that the IMU-II/S's battery not be changed until the IMU-II/S has reported a low battery alarm for 7 consecutive days.

Lithium Battery Replacement

1. Plug the replacement lithium battery pack onto the spare battery connector (J3 or J4).
2. Unplug the discharged lithium battery pack and remove it from the battery holder.
3. Place the replacement lithium battery pack into the holder, and secure it with the tie wraps.

NOTES

CHAPTER SEVEN: RETURN EQUIPMENT PROCEDURE

INTRODUCTION

If you should encounter a problem with the IMU-II/S, this chapter explains the procedure to return equipment to Metrotek.

RETURN EQUIPMENT PROCEDURE

In order to return any equipment for repair or upgrades, contact your local distributor first for assistance. Complete the checklist contained on the next page and return it with the equipment package. Within Australia the local contact information is provided below:

Remotek Pty. Limited
Suite-J
680 Pacific Highway
Killara NSW 2071
61 (2) 9989-8991
www.remotek.com.au

In order to return any equipment directly to Metrotek, please contact Metrotek's Customer Service Department at (321) 259-9700 and obtain a return authorization (RA) number. The address for Metrotek within the United States is provided below:

Metrotek, Inc.
305A East Drive
Melbourne, Florida (USA) 32904
Telephone: (321) 259-9700
Fax: (321) 259-2900
www.metrotekfl.com

Note: It may be necessary to dial a country code first depending upon whether the call is originating from Australia or New Zealand.

IMU-II/S FAILURE CHECKLIST

Customer: _____ RA No.: ____

AIS No.: __ Serial No.: __ Reported By: _____

Date IMU-II/S Removed: ____ Location: _____

Last Call Date and Time: _____

Please indicate the reason /symptom(s) of the failure below:

1. Communications unsuccessful at any stage of call procedure.

- Unit will not dial.
- Unit will dial, but no data is transmitted or received.
- Unit will not answer.

2. Unit calls excessively. State the alarms that caused unit to have excessive calls:

3. Other (please be specific): _____

Visual Inspection: _____

Please enclose this checklist with the IMU-II/S being returned to:

Metrotek, Incorporated
 305A East Drive
 Melbourne, FL 32904

APPENDIX A: PRODUCT SPECIFICATIONS

<u>Parameter</u>	<u>Specification</u>
Operating Temperature Range	-30 to +70 C
Enclosure Specifications:	
Height	6.5 inches (16.5 cm)
Width	6.9 inches (17.5 cm)
Depth	4.3 inches (10.9 cm)
Weight	2.5lb / 1.10Kg (including lithium battery).
Power Supply:	
Battery Powered	Lithium battery, 3.6VDC, 11.5 Ahr.
Typical Battery Life:	
Battery Powered	3 years nominal. Battery life is dependent on number and state of the pulse / alarm inputs, number of calls, and the operating temperature.

Telephone Interface Specifications:

Ringer Equivalence	0.5
Austel Approval Number	N11487
Pulse Dialing Mode:	
Dial Rate	10 pulses / second
Percent Break	60%
Interdigit Interval	800ms
Dialing Digits	31 (maximum)
DTMF Dialing Mode:	
Deviation from standard tone	0.73% maximum
Dial Rate	3.3 digits / second
Interdigit Interval	150ms
Output Level	-7.8dBm (nominal)
Dialing Digits	31 (maximum)
Pause Mode	Programmable
Communication Signals:	
Modulation Standards	CCITT V.22bis (2400 bps) CCITT V.22 (1200 bps) Bell 212A (1200 bps) Bell 103 (300 bps)
Data Output Level	Less than -9dBm (fixed)
Modem Sensitivity	-40dBm (minimum)
Telephone Connector	4-conductor RJ-11C
Data Storage Capacity	32K RAM (»28K for Time Tagged Intervals)
Serial Inputs:	
Type	RS-232C
Baud Rate	300, 1200, or 2400 bps
Data Bits	7 or 8
Stop Bits	1, 1.5, or 2
Parity	Even, Odd, or None
Contact Closure Inputs:	

Tamper Alarm	Form-B (normally closed, transition to open triggers alarm) TB1-6, TB1-7
Data Input 1	Form-A (normally open, transition to closed causes a pulse to TB1-3, TB1-5
Data Input 2	Form-A (normally open, transition to closed causes a pulse to TB1-4, TB1-5
Alarm Input	Form-A (normally open, transition to closed, causes an alarm to TB1-1, TB1-2
Maximum Voltage Drop / Resistance (switch + cable, switch on)	0.8VDC maximum, 1000 ohms maximum
Active State	Must be active for greater than 40ms. (Inputs must be
Data Input Rate	600 counts / minute maximum
Wetting Voltage per Input	3 to 5 volts (nominal)
Wetting Current per Input	175uA (nominal)

NOTES

APPENDIX B: TII STATION PROTECTOR

METRETEK

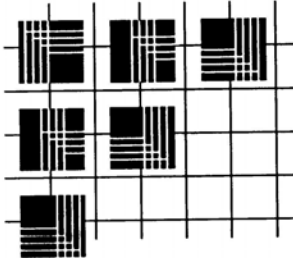

TII STATION PROTECTOR



STATION PROTECTION

TII Station Protection products provide premium surge protection for a wide range of telephone applications. TII's patented Total Failsafe® construction and 3-electrode gas tubes create protection devices that will survive the toughest of environments.

Each of our 2 or 3-electrode station protectors satisfy the missing protector requirement that is rapidly becoming industry standard and is only one of the many ways TII serves your protection needs. In the following pages you will see some of our other exciting product ideas.



Dimensions: 3.63" x 3" x 2.38"
Weight: 6.0 oz (one pair)
8.10 oz. (two pair)
Standard Package: 50 pieces

**TII 325 TFS® TOTEL FAILSAFE® MAXIMUM DUTY
TII 326 TFS® TOTEL FAILSAFE® HEAVY DUTY
ONE OR TWO PAIR STATION PROTECTORS
(Patent No. 4,212,047)
UL LISTED, REA ACCEPTED PER PE-80**

The TII 325 and TII 326 house one or two TII TFS® Station Protector Modules on a convenient mounting base with cover. Two No. 10 binding posts are provided on each protector module for tip and ring. A No. 10 binding post is molded into the base for ground connection.

Units may be ordered with a single protector module and a second TII protector module may be added in the field to upgrade the protector assembly for two pairs. They may also be purchased with two modules installed.

All units are equipped with a plastic cover complete with plastic mounting nut and a rubber grommet in the base for wire entrance. The TII 325 comes with the TII 355 Maximum Duty station protector modules installed. The TII 326 comes with the TII 356 Heavy Duty station protector modules installed. Please see the next page for electrical specifications.

MODEL	DESCRIPTION
TII 325 1()	Single Pair Maximum Duty Station Protector
TII 325 2()	Two Pair Maximum Duty Station Protector
TII 326 1()	Single Pair Heavy Duty Station Protector
TII 326 2()	Two Pair Heavy Duty Station Protector

Please insert letter L or M in place of ().

M designates a protector module meeting the REA, PEG and other industry requirements.

L designates a protector module meeting specific Bell System requirements.

Both L and M type station protectors are UL Listed

TII Station Protector

NOTES

Index

A

Abbreviated terms 1-6
AC Powered IMU-II/S 3-10
American wire gauge 1-6
AWG 1-6

B

Battery
Connectors 6-1
Install lithium battery 3-10
Maintenance 6-1
Passivation layer 2-5, 6-2
Resistor 2-5, 6-2
Battery replacement
Lithium 6-1
Bushing 3-3

C

Cables, install
Alarm cables 3-5
Grounding cable 3-4

D

Dual Port IMU-II/S 1-1

E

Equipment setup 2-4

F

FCC-required notifications 1-4

G

Grounding cable, attach 3-3

I

IMU-II/S 1-2
IMU-II/S layout 2-1, 2-2
IMU-II/S Operations 4-1
Industrial Metering Unit Model II/S 1-2
Install cables 3-3

L

LED 1-6
LED Functions 3-14
Light emitting diode 1-6
List of materials
Provided by customer 2-3
Provided by Metretek 2-3
Purchased from Metretek 2-3
List of tools 2-4
Lithium batteries 3-10

M

Magnetic switch 3-13
Maintenance, battery 6-1
Materials 2-1
Metretek programmer software 2-3
Mount equipment 3-2
Mounting dimensions 3-2

P

Power Source, install
AC Power 3-10
Lithium Battery 3-10
Passivation layer 2-5, 6-2
Program IMU-II/S 3-11

R

Reference documents
CDOC notifications 1-2
FCC-required notification 1-4
Warranty information 1-2
Return authorization (RA) number 6-1
Return equipment procedure 6-1

S

Serial Data Connection 3-8
Serial Port Multiplexer Connection 3-9
Setup of equipment 2-4
Storage of batteries 2-5

T

Terminal strip, IMU-II/S 3-6
TII telephone station protector
Earth ground 3-3
Telephone cables 3-3
Wiring 3-3
Tools 2-4
Troubleshooting
Battery voltage, check 5-1
Telephone cable 5-1

W

Warranty information 1-3